

# INSTALLATION MANUAL



[www.s4mountingsystem.com](http://www.s4mountingsystem.com)

**S4<sup>®</sup> RooFit<sup>™</sup>**

Universal Mounting System



## Table of Contents

A Universal System	Page 3
S4 Kit System	Page 4
Accessories – Accessories for Flashing	Page 5
Tools required for installation	Page 6
Mounting System	Pages 7 to 11
Online Configurator	Page 12
Site Preparation	Pages 13 to 15
Fixing Areas	Pages 16 to 30
Lower PV Field – Roof & Eaves Interfaces	Pages 31 to 39
Upper PV Field – Roof & Eaves Interfaces	Pages 40 to 41
Cable Routing	Pages 42 to 43
Implementation	Page 44
Installation Step by Step	Pages 45 to 66
Tolerance	Page 67
Universal Intermodule	Page 68
Screw Fastening	Page 69
Maintenance	Page 70
Assistance & Contact	Pages 71 to 72





# a universal system



The S4 Mounting System is compatible with all roofing types, including curved tiles, mechanical tiles, flat tiles, slates, metal and standing seam roofs. It can be installed on both new constructions and renovation projects.

This installation manual provides general installation principles and best practice guidance. The installer remains responsible for verifying site specific conditions, structural adequacy, compliance with local regulations, and suitability of the roofing system.

The S4 Mounting System supports both portrait and landscape orientations using a Universal mounting tray compatible with both formats.

It is suitable for small installations (less than 3 kWp) as well as large roofs (up to several hundred kWp).

#### **Compatibility and Installation Options:**

- Can be installed on wood or metal structures.
- Mountable on battens, lathing, or plywood.
- Suitable for pitched roofs with angles between 12° and 70°

#### **Fire performance**

Classifications apply only to the tested configuration (module + mounting system + roof build-up). Any deviation requires confirmation.

#### **Warranty and Maintenance:**

- 10-year warranty if installation guidelines are followed.
- Low maintenance required, limited to regular cleaning of the solar panels.

**Roofing works must be carried out by a competent roofing professional.**

### FULL S4 KIT SYSTEM



S4 TRAY



HORIZONTAL  
EXTENSION



VERTICAL  
EXTENSION



HORIZONTAL  
EXTENSION

### Accessories for Assembly



STAINLESS STEEL SCREW FOR CLAMPS  
6.5 X 60MM + EPDM WASHER



SINGLE CLAMPS  
WITH EPDM



DOUBLE CLAMPS  
WITH EPDM



LATERAL FLASHING



FLASHING HOOKS



HEXAGONAL HEAD SCREW  
6.5 x 25 mm for fixing the tray.



BY COUNTRY  
UNIVERSAL INTERMODULE  
BLACK

### WATERPROOFING



17 WATERPROOFING STRIP



PRECOMPRESSED  
SEAL ROLL 20X40MM



STANDARD ROOF  
UNDERLAY SCREEN

## REQUIRED TOOLS

### Tools required for installation

#### ■ CHALK LINER



#### ■ HAMMER



#### ■ SCREWDRIVER TORQUE WRENCH (ADJUSTABLE)



#### ■ TRAY SHEAR



- WOOD AND METAL DRILL BIT  $\varnothing$  10 mm
- 8MM SOCKET BIT

#### ■ MEASURING TAPE – WHITE MARKER OR PENCIL



### A Simple Overlapping System



TOP VIEW, OVERLAPPING OF THE TRAYS



REINFORCED BOTTOM VIEW

Adjustable to fit the size of PV Panels with the graduated Overlapping Zone



GRADUATED OVER LAPPING ZONE

Adjustable to fit the size of PV Panels by adding Vertical Extensions

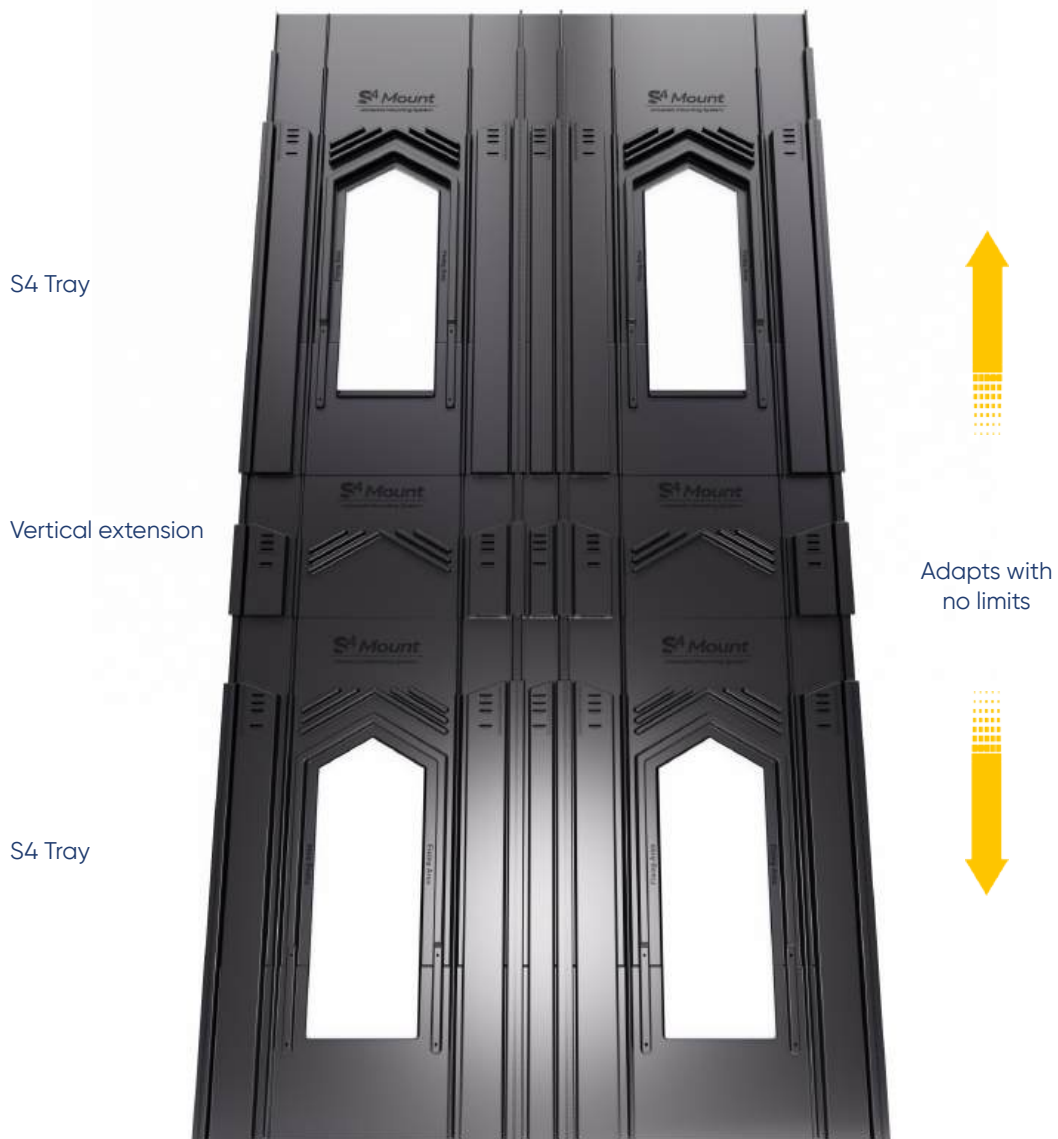

Compatible with all panel heights without limits

Adjustable to fit the size of PV Panels by adding Horizontal Extensions



← Adapts with no limits →

Compatible with all panel widths without limits

#### Upper Roof Integration of S4 Trays Using the S4 Height Riser

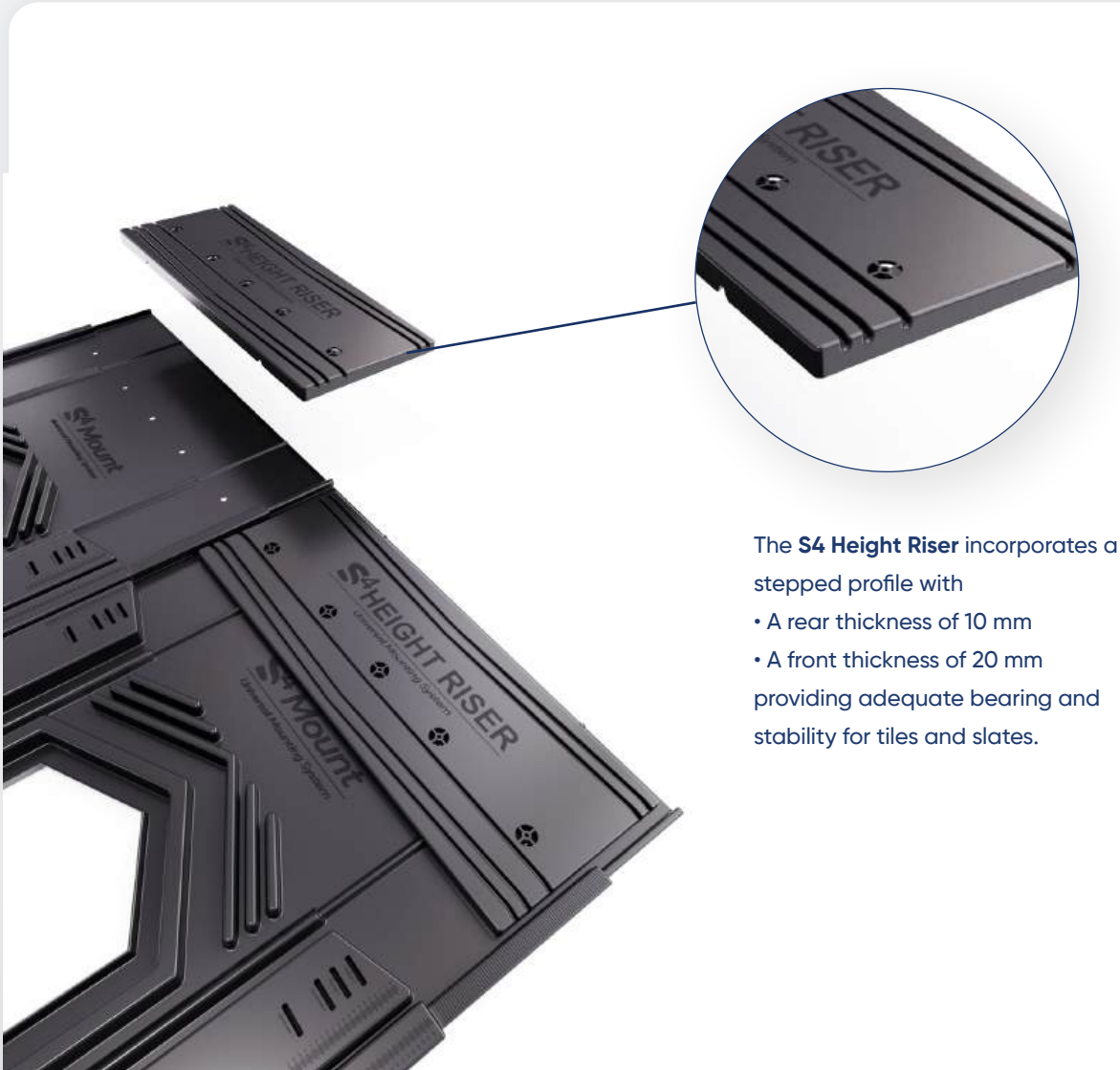

The **S4 Height Riser** incorporates a stepped profile with

- A rear thickness of 10 mm
- A front thickness of 20 mm providing adequate bearing and stability for tiles and slates.

The upper roof covering (tiles or slates) shall overlap the S4 Height Riser by a minimum of 60 mm to ensure proper weathering and drainage

## FASTENING INSTRUCTIONS



## INSTALLATION PROCEDURE USING THE S4 MOUNTING SYSTEM APPLICATION

### 1- Application Access

- Launch the S4 Mounting System application from your mobile device or computer
- Log in using your credentials

### 2- Project Parameters Input

- Enter the building orientation
- Specify the roof slope
- Define the intended location of the photovoltaic system

### 3-Automatic Analysis The application performs calculations based on:

- Your geographical location
- Current Eurocode standards

### 4-Generated Results The application automatically provides:

- Required number of mounting clamps for the installation
- Detailed specifications for supporting batten implementation

### PRE-INSTALLATION SITE WORK

#### SITE SURVEY AND STRUCTURAL VERIFICATION BEFORE INSTALLATION

By using the S4 RooFit mobile application on site, the user's location will be automatically detected. Once the project configuration parameters are entered, the application will calculate the required number of clamps and generate detailed installation instructions. Additional reference data is provided below if needed.

Prior to installation, the **installer must carry out measurement work to ensure the long-term durability and performance of the PV array.**

The project's climatic conditions (e.g., wind and snow) and the PV array layout must be considered in accordance with applicable standards (Eurocode and BS 5534).

These data will assist in verifying whether the system is suitable for the specific project conditions. The thickness of the support battens must also be adapted to the roof battens to ensure a watertight junction with the roof covering.

#### 1- CLIMATIC CONDITIONS

Assessment of climatic loads in compliance with Eurocode 1 and BS 5534.



Geographical Wind Zones	Design Wind Pressure, $P_u$ , for underlay ( $N/m^2$ )
Well sealed ceiling (e.g. Standard domestic applications)	Minimum Requirements
Zone 5	1 600
Zone 4	1 330
Zone 3	1 150
Zone 2	975
Zone 1	820
Not sealed ceiling or non-ceiling (e.g. Garage or warehouse)	1 900
Not sealed ceiling or non-ceiling in addition to permanent structural opening (e.g. Car port or open store)	2 350

#### ! IMPORTANT NOTE

The results provided by the S4 RooFit application are indicative only and depend on the parameters entered by the user. The installer and/or project owner remain responsible for verifying site-specific conditions and regulatory compliance. Where required, the installation shall be checked and approved by a competent structural engineer.

### PRE-INSTALLATION SITE WORK

#### 2- PV ARRAY LAYOUT ON THE ROOF

The location of the PV array on the roof (center, edge, or corner) significantly impacts the applied wind load. Calculations should be based on the most unfavorable condition.

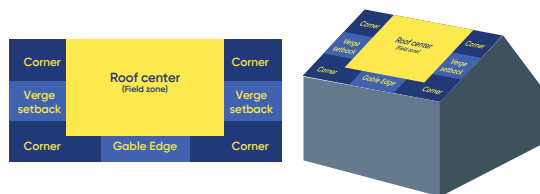

DUAL-PITCH ROOF

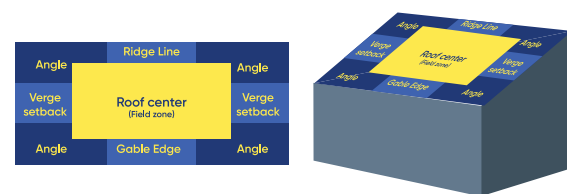

MONO-PITCH ROOF

#### 3- DETERMINATION OF PROJECT-SPECIFIC WIND PRESSURE AND CALCULATION OF THE NUMBER OF CLAMPS PER MODULE

To calculate the wind load applied to the PV array, it is essential to first define the following project parameters:

- Project location,
- Altitude,
- Terrain type,
- Distance from the shoreline,
- Ridge height,
- Roof pitch,
- Roof zone classification (Center, Edge, Corner).

#### CLAMPS TO BE INSTALLED

Ideally, wind and climatic loads should be individually assessed for each specific project. However, if all the conditions match the criteria detailed below, the indicative tables provided can be used as a reference.

### PRE-INSTALLATION SITE WORK



#### FIXED CONDITIONS:

- Rural terrain (including suburban terrain)
- Distance from Shoreline: 10 km,
- Battens Dimension: 25 x 50 mm.



#### WIND UPLIFT RESISTANCE FOR S4 ROOFIT

(PORTRAIT & LANDSCAPE configurations based on BBA Testing):



#### RESULTS

-  • 4 Clamps: 3.42 kN/m<sup>2</sup>,
-  • 8 Clamps: 3.8 kN/m<sup>2</sup>.

**SAFETY FACTORS: 1,10**  
(Safety factor = Result / 0.90)

-  • 4 Clamps: 2.37 kN/m<sup>2</sup>
-  • 8 Clamps: 3.11 kN/m<sup>2</sup>

**SAFETY FACTORS: 1,44**  
(Safety factor = Result / 0.56)

-  • 4 Clamps: 1.81 kN/m<sup>2</sup>
-  • 8 Clamps: 2.38 kN/m<sup>2</sup>

#### 1<sup>ST</sup> CASE: ROOF PITCH ≥ 25°

Ridge Height	Location on the Roof	Zone 1 (Alt ≤ 250m)	Zone 2 (Alt ≤ 200m)	Zone 3 (Alt ≤ 130m)	Zone 4 (Alt ≤ 100m)	Zone 5 (Alt ≤ 50m)
6 m	Center	1,26 kN	1,38 kN	1,44 kN	1,58 kN	1,65 kN
	Edges	1,46 kN	1,60 kN	1,67 kN	1,83 kN	1,92 kN
	Corners	1,56 kN	1,72 kN	1,78 kN	1,94 kN	2,05 kN
8 m	Center	1,37 kN	1,51 kN	1,57 kN	1,72 kN	1,84 kN
	Edges	1,59 kN	1,75 kN	1,82 kN	1,98 kN	2,09 kN
	Corners	1,71 kN	1,87 kN	1,95 kN	2,14 kN	2,24 kN
10 m	Center	1,43 kN	1,57 kN	1,63 kN	1,79 kN	1,88 kN
	Edges	1,66 kN	1,82 kN	1,90 kN	2,08 kN	2,18 kN
	Corners	1,78 kN	1,95 kN	2,03 kN	2,23 kN	2,33 kN

**Valid until 31/01/26**

#### 2<sup>ND</sup> CASE: ROOF PITCH ≥ 35°

Ridge Height	Location on the Roof	Zone 1 (Alt ≤ 250m)	Zone 2 (Alt ≤ 200m)	Zone 3 (Alt ≤ 130m)	Zone 4 (Alt ≤ 100m)	Zone 5 (Alt ≤ 50m)
6 m	Center	1,09 kN	1,19 kN	1,29 kN	1,36 kN	1,43 kN
	Edges	1,36 kN	1,49 kN	1,61 kN	1,71 kN	1,78 kN
	Corners	1,43 kN	1,57 kN	1,69 kN	1,79 kN	1,87 kN
8 m	Center	1,19 kN	1,30 kN	1,40 kN	1,47 kN	1,56 kN
	Edges	1,48 kN	1,63 kN	1,75 kN	1,86 kN	1,94 kN
	Corners	1,56 kN	1,71 kN	1,84 kN	1,95 kN	2,04 kN
10 m	Center	1,24 kN	1,36 kN	1,46 kN	1,55 kN	1,63 kN
	Edges	1,55 kN	1,69 kN	1,83 kN	1,94 kN	2,03 kN
	Corners	1,62 kN	1,78 kN	1,92 kN	2,04 kN	2,13 kN

**Valid until 31/01/26**

### PANELS ORIENTATION

LANDSCAPE MODE



PORTRAIT MODE



With the universal S4 mounting system, determine and choose the optimal orientation with the online S4 configurator.

### ■ PORTRAIT INSTALLATION MODE



■ TRAYS' FIXING AREAS

### ■ PORTRAIT INSTALLATION MODE

#### PORTRAIT 2 SETTING

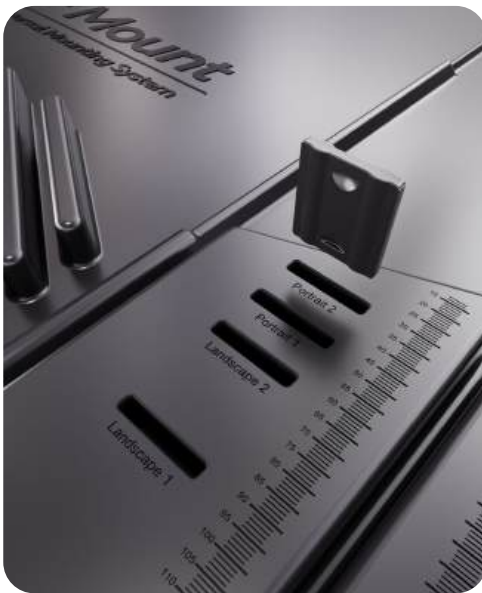

#### ■ PHOTOVOLTAIC PANEL SUPPORT

On the first row of S4 trays, behind each photovoltaic panel, insert the fixing clamps to secure the panel in position. Use the "Portrait 2" setting, intended for a standard portrait installation.

### ■ PORTRAIT INSTALLATION MODE

■ TRAYS' FIXING AREAS

■ CLAMPS' FIXING AREAS

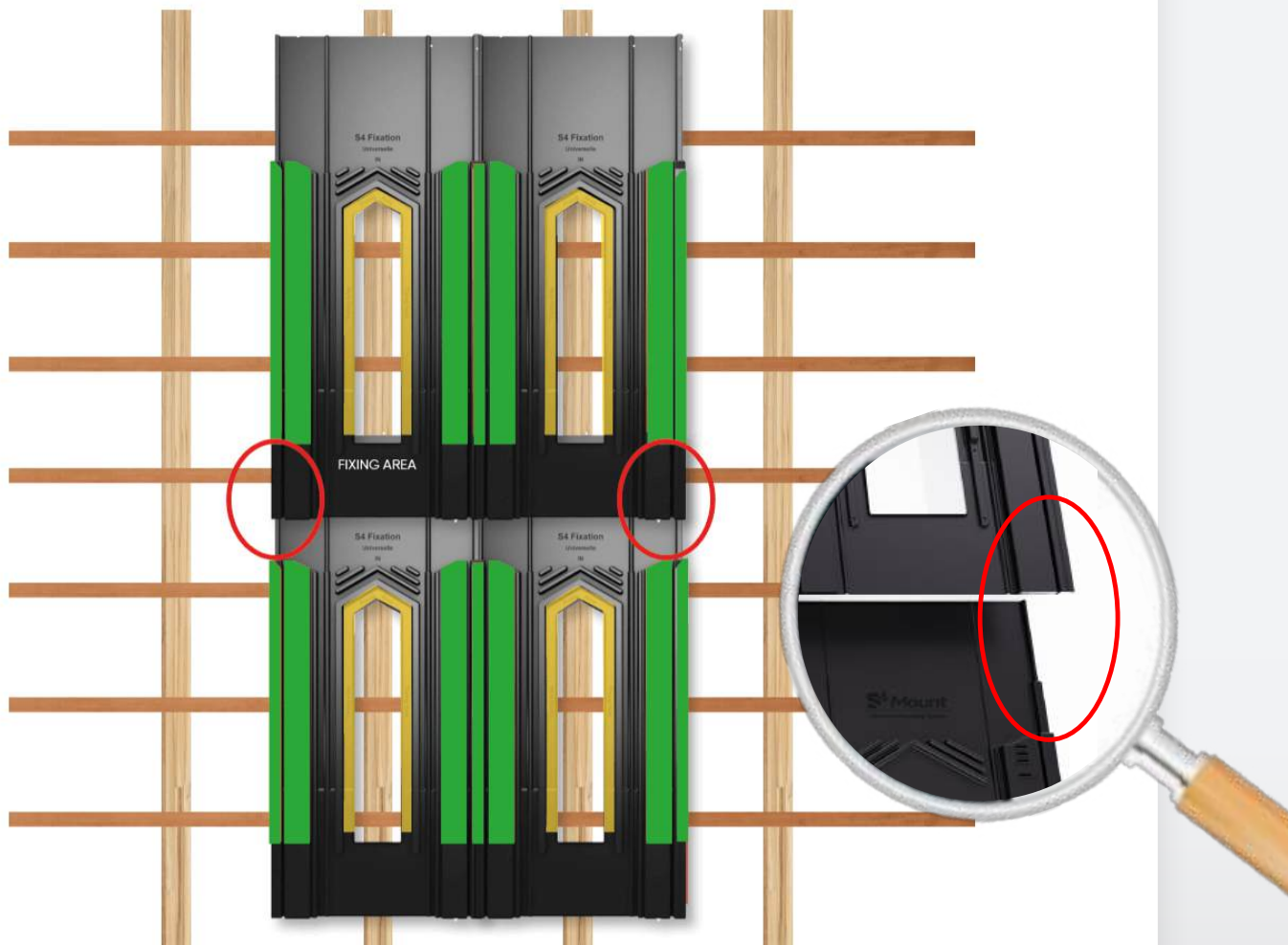

#### INSTRUCTIONS



Fasten the S4 mounting tray to the timber structure using Hexagonal Head Screws 6.5x25mm. This screw can be used on both wooden and metal structures.

**USE THIS SCREW IF YOU WANT TO FIX THE TRAYS TOGETHER.**

#### ⚠ IMPORTANT

It is strictly **forbidden to install a clamp** in the overlap area between two S4 Mounting trays.

**Any fastening in this area will compromise** both the watertightness and the mechanical integrity of the system

### ■ PORTRAIT INSTALLATION MODE

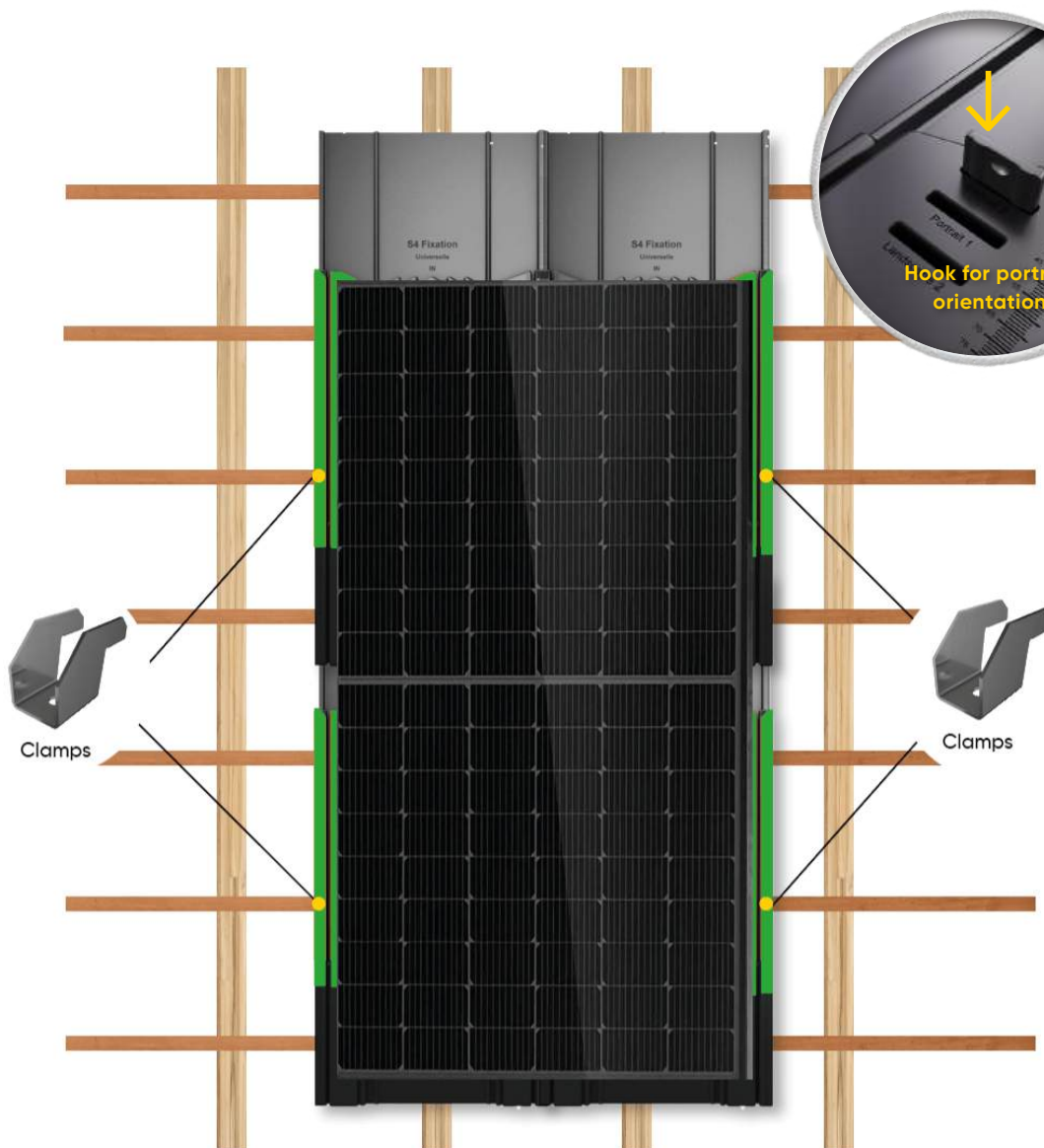

■ CLAMPS' FIXING AREAS

### LANDSCAPE INSTALLATION MODE

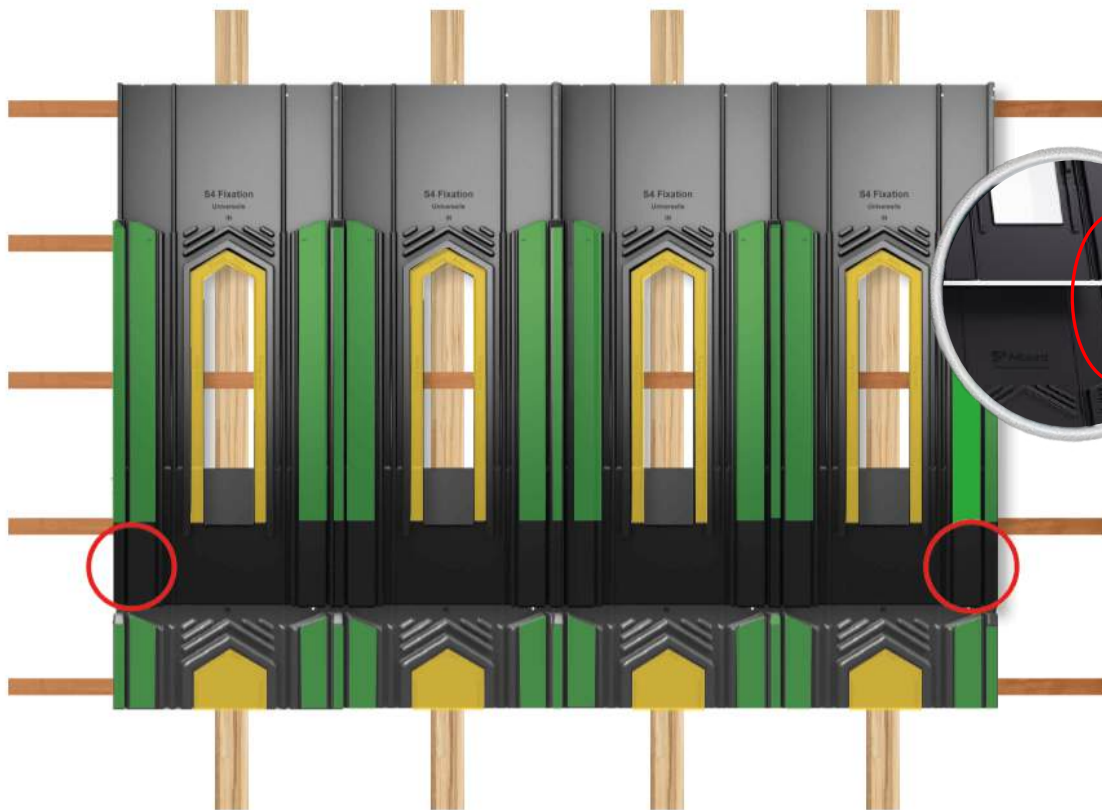

 TRAYS FIXING AREAS

 CLAMPS FIXING AREAS

#### INSTRUCTIONS



Fasten the tray to the timber structure using Hexagonal Head Screws 6.5x25mm. This screw can be used on both wooden and metal structures.

**USE THIS SCREW IF YOU WANT TO FIX THE TRAYS TOGETHER.**

#### IMPORTANT

It is strictly forbidden to install a clamp in the overlap area between two trays. Any fastening in this zone would compromise both the watertightness and the mechanical integrity of the system.

### LANDSCAPE INSTALLATION MODE

#### LANDSCAPE 2 SETTING



#### PHOTOVOLTAIC PANEL SUPPORT

On the first row of S4 trays, behind each photovoltaic panel, insert the fixing clamps to secure the panel in position. Use the "Landscape 2" setting, intended for a standard Landscape installation.

### LANDSCAPE INSTALLATION MODE

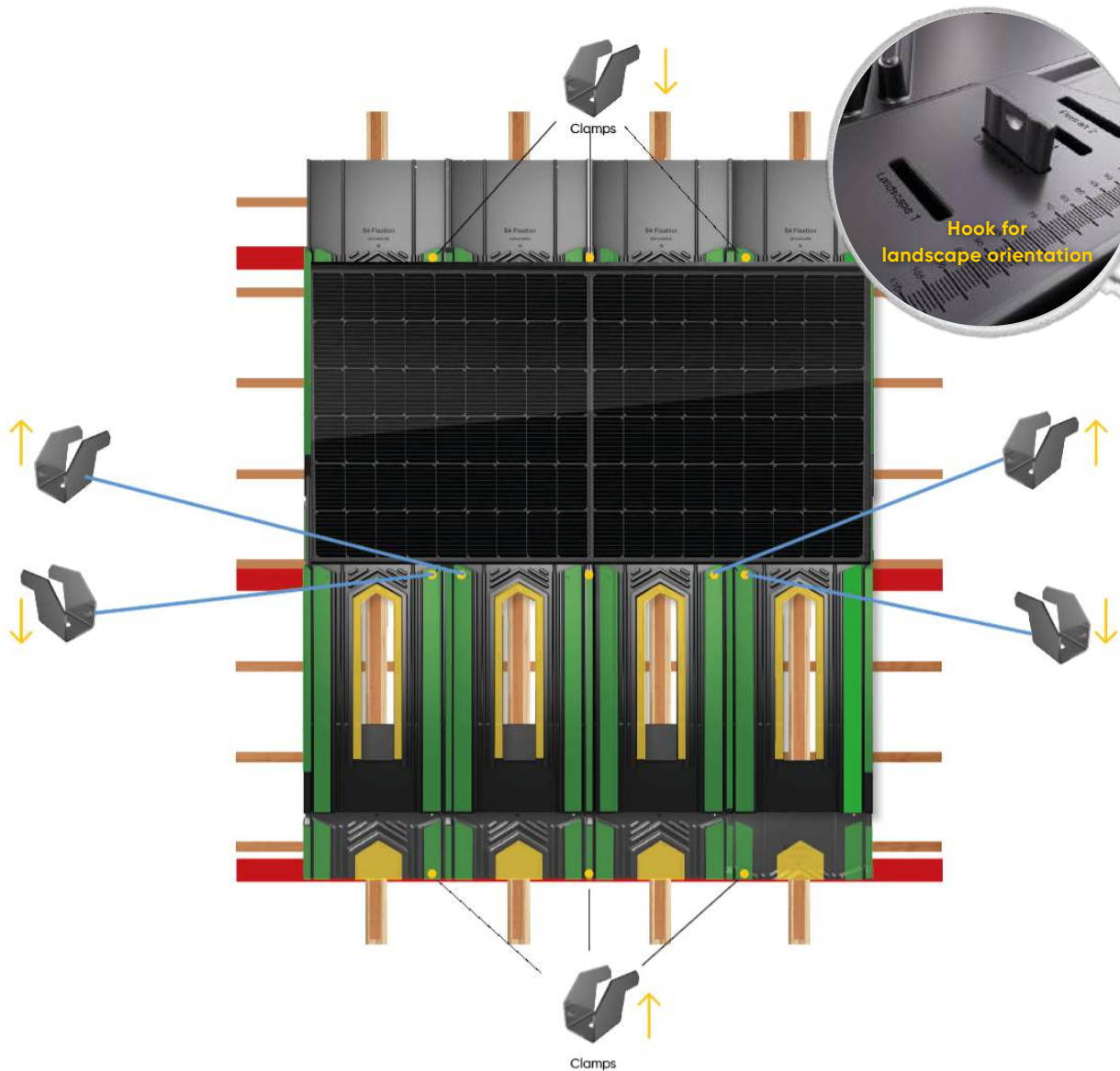

**CLAMPS FIXING AREAS**

IN LANDSCAPE ORIENTATION, FIX THE BOTTOM CLAMP TO THE S4 TRAY BELOW, WHICH SUPPORTS THE NEXT PANEL IN THE COLUMN.

### LANDSCAPE INSTALLATION MODE

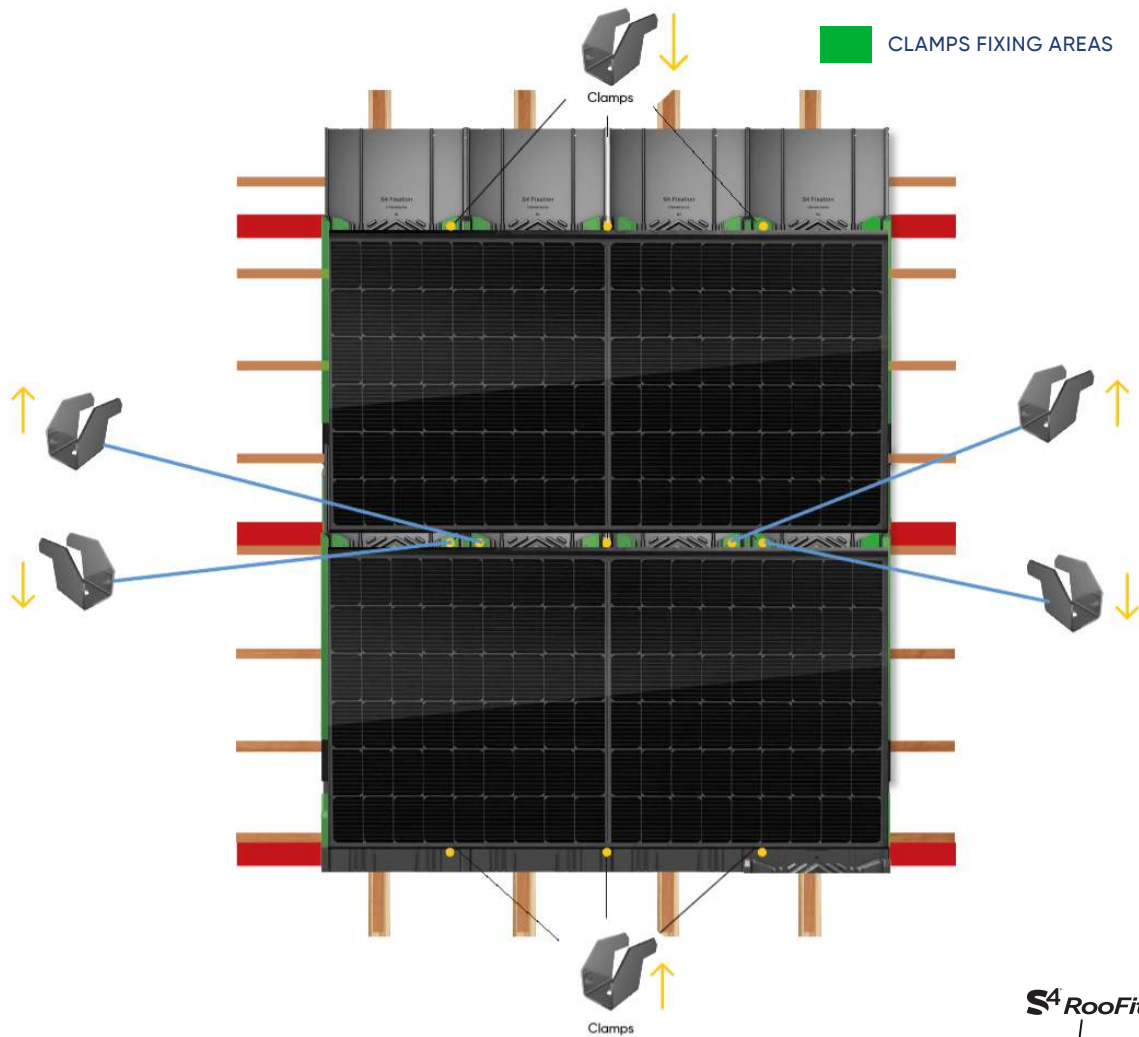

On the last row of the column, extend at least 110 mm beyond the lower edge of the photovoltaic panel in order to:

- Allow secure fixing of the final row of mounting clamps
- Comply with the required overlap rules when installing flexible or rigid flashing systems
- Ensure continuity of water drainage and weatherproofing at the lower edge of the photovoltaic array

This value is provided for guidance only and shall be adjusted depending on the roof pitch, roofing type and applicable roofing rules and standards.

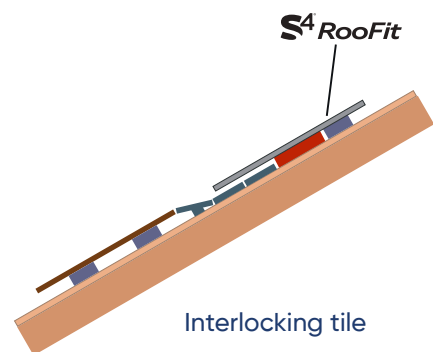

### ■ SIMPLE AND DOUBLE CLAMPS

Depending on the size of your solar panel, the number of battens present and their spacing, you may choose either a configuration using single clamps or double clamps.



Single Clamp

Equipped with a 2.5 mm thick EPDM



Double Clamp

Equipped with a 1.7 mm thick EPDM

### ■ SINGLE VS DOUBLE CLAMP

When the "double clamp" option is selected, the number of clamps required will be doubled compared to an installation using single clamp.

This reinforcement compensates for the mechanical forces distributed between two adjacent columns and ensures a mechanical performance equivalent to that obtained with correctly spaced single clamp.

Based on the technical data provided (postcode, roof height and pitch, wind exposure, and position of the photovoltaic array), the S4 configurator automatically determines the required number of clamp.

This recommendation applies to both single-clamps and double-clamp configurations.

### SINGLE CLAMP ARE SUPPLIED WITH A 2.5 MM EPDM GASKET

#### ■ PORTRAIT INSTALLATION

#### ! IMPORTANT

The installation of the lateral flashing creates an additional thickness of approximately 0.8 mm. In this configuration, the 2.5 mm gasket must not be used. You must replace it with the 1.7 mm EPDM gasket, supplied separately with the single clamp.

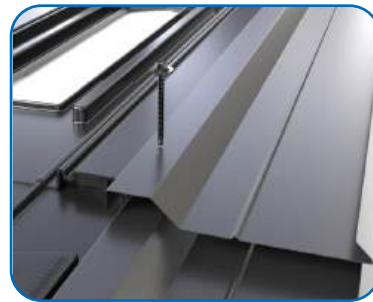

Lateral Flashing



Single Clamp



EPDM (70 Shore A hardness)

#### ! IMPORTANT

It is essential to follow this procedure carefully to ensure:

- Correct tightening of the clamp,
- Proper support on the tray,
- Optimal mechanical performance of the system.

#### ✓ LANDSCAPE INSTALLATION

No flashing is installed underneath the clamp meaning no additional thickness is created.

In this case, you must use the standard 2.5 mm EPDM gasket supplied pre-mounted on the single clamp.

### DOUBLE CLAMPS ARE SUPPLIED WITH A 1.7 MM EPDM GASKET.

#### IMPORTANT

It is mandatory to keep this gasket in place.  
The 1.7 mm thickness is specifically designed to ensure:

- Proper seating of the clamp on the tray
- Correct tightening without deformation
- Optimal mechanical performance
- Long-term durability of the installation

**Do not replace or modify this gasket.**

**Any alteration may compromise the mechanical integrity and watertightness of the system.**



Double Clamp

Equipped with a 1.7 mm thick EPDM

#### INFORMATION

When the “**double clamp**” option is selected, the number of clamps to install will **naturally be doubled** compared to an installation using single clamps.

This **reinforcement compensates** for the mechanical forces distributed between **two adjacent columns** and ensures a **mechanical performance** equivalent to that obtained with **correctly spaced single clamps**.

Based on the technical data provided (postcode, roof height and pitch, wind exposure, and position of the photovoltaic array), the **S4 configurator automatically determines the required number of clamps**. This recommendation applies to **both single-clamps and double-clamp** configurations.

### CLAMP FIXING AREA

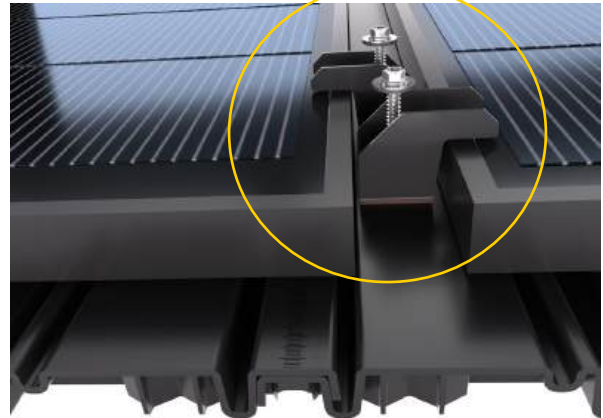
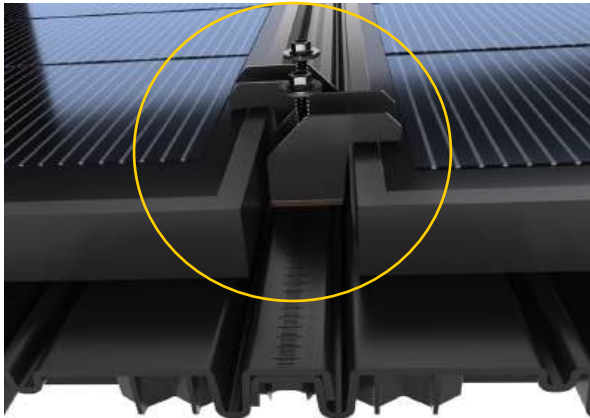
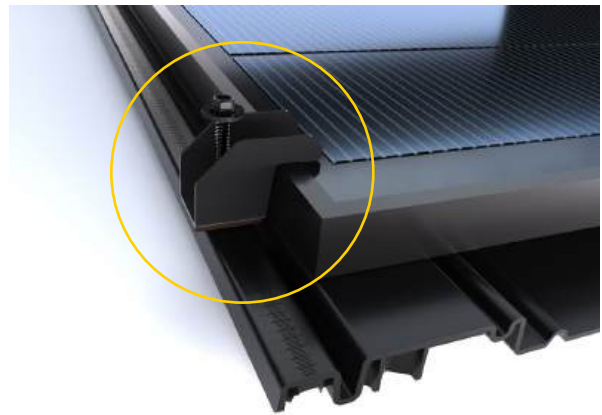

#### IMPORTANT

Fix your clamps to the central overlap wave or one of the reinforced areas.

### PROHIBITED FIXING ZONES – WATER DRAINAGE PROTECTION



#### WARNING



Any fastening, drilling, or penetration in the water drainage zone is strictly prohibited. This area is designed to channel rainwater and ensure watertight performance of the roof system.

Any mechanical intervention in this zone may lead to water infiltration, structural damage, or voiding of product warranties.

### PROHIBITED FIXING ZONES



#### IMPORTANT

It is strictly forbidden to install a clamp in the overlap area between two trays. Any fastening in this zone would compromise both the watertightness and the mechanical integrity of the system

## INSTALLATION OF LOWER PV FIELD

### LOWER PV FIELD ROOF & EAVES INTERFACES

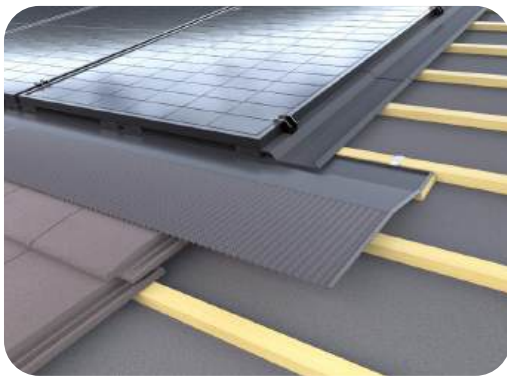

Lower Semi-Rigid Flashing

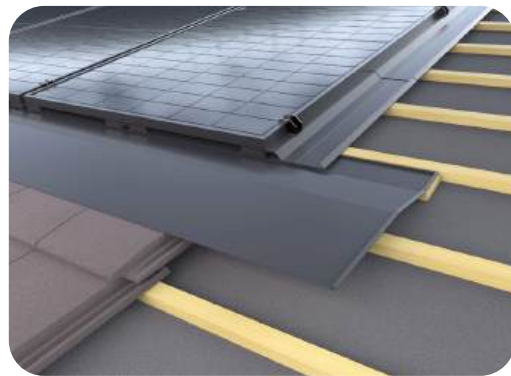

Lower Rigid Flashing



Eaves Flashing

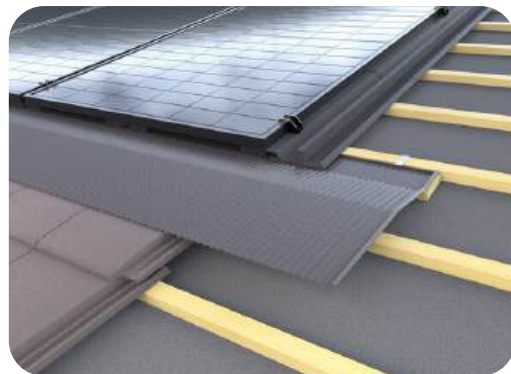

Flashing Strip

#### IMPORTANT NOTE

The overlap between the **S4 trays** and the **flashing components** (including flexible, semi-rigid and rigid flashing systems) must be **determined in accordance with good roofing practice**, taking into account **the roof pitch**, to ensure **correct weathering** and **water run-off**.

Roofing works, including the selection and determination of the **appropriate overlap for all flashing types**, must be **carried out by a competent roofing professional**.

### EAVES AND FLASHING INSTALLATION

#### INSTALLATION OF THE LOWER SEMI-RIGID FLASHING

Compatible with all types of interlocking tiles, except high-profile tiles

##### STEP 1 - Lateral corners

Form right- and left-hand corners by folding the lateral edge by 20 mm to create a vertical water barrier. Do not fully compress the fold; maintain a 2–3 mm clearance to allow material flexibility and thermal movement.

##### STEP 2 - Flashing installation

Install flashings from right to left, following water run-off. Fasten using integrated fixing tabs only, directly into the supporting battens. No fixings are permitted in overlap zones.

##### STEP 3 - Flashings shall overlap until upper folds meet.

Minimum overlap: 170 mm, increased as required according to roof pitch and exposure. Bond flexible sections to ensure continuous drainage. No additional sealant is required.

##### STEP 4 - Butyl strip

Apply the integrated butyl strip onto clean, dry roof tiles. Use a pressure roller to ensure uniform adhesion.

##### STEP 5 - Waterproofing principle

Watertightness is achieved by flashing geometry, overlaps and gravity drainage. The butyl strip provides secondary sealing only and does not replace correct overlap design.

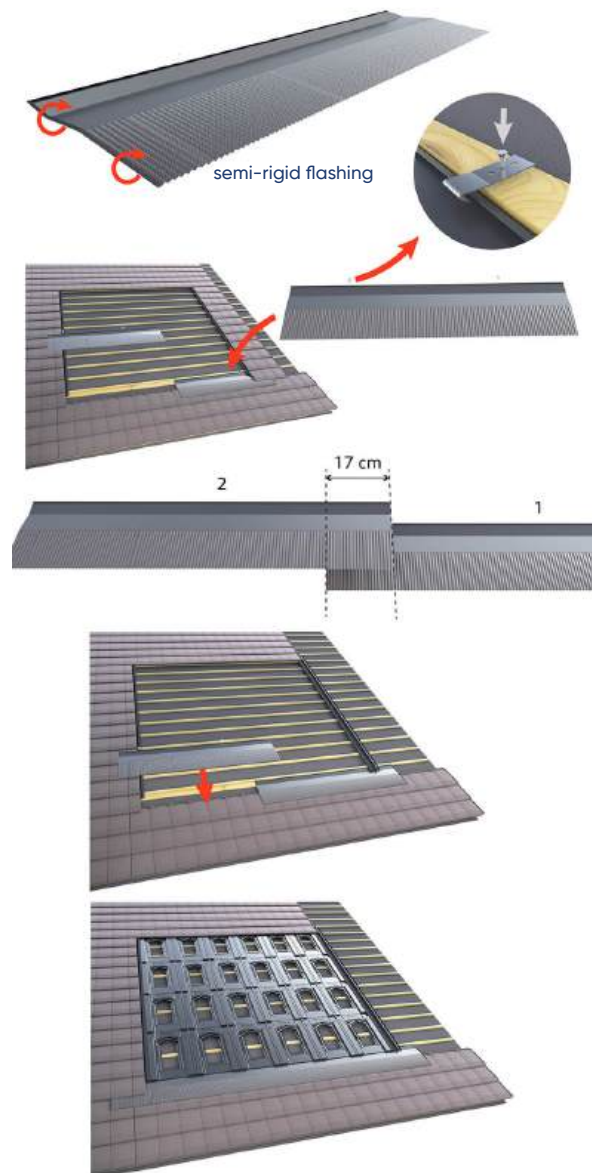

### EAVES AND FLASHING INSTALLATION

#### INSTALLATION OF THE LOWER SEMI-RIGID FLASHING

Compatible with all types of interlocking tiles, except high-profile tiles

##### PREPARATION OF BATTENS

###### Lower PV Field Connection

Support battens must be installed to receive the rigid or semi rigid flashing forming the weatherproof junction between the lower edge of the PV array and the roof covering, in accordance with BS 5534, NHBC Technical Requirements and BBA-accepted roofing practice.

The flashing ensures continuity of waterproofing and gravity-driven drainage onto the lower roof covering.

##### REQUIREMENTS:

- Maximum batten thickness: 18 mm,
- Batten geometry adapted to roof pitch (no counter-slope)
- Batten layout defines the clearance between the PV field and the roof covering.

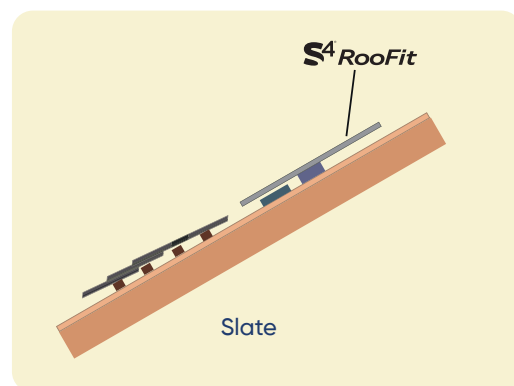
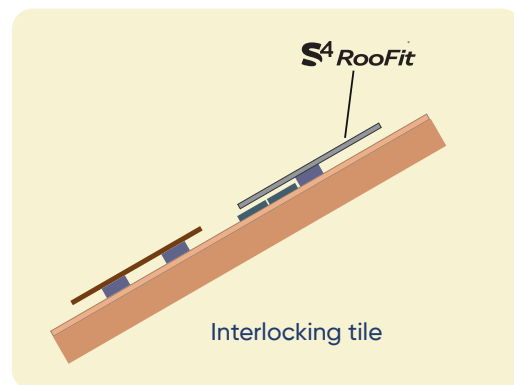

### EAVES AND FLASHING INSTALLATION

#### INSTALLATION OF THE LOWER RIGID FLASHING FOR FLAT TILE OR SLATE ROOFS

##### Step 1 - Right-hand corner

Form a 20 mm lateral return to create a water barrier.  
Position at the lower right of the PV array.  
Fasten the left edge only with two corrosion-resistant screws into the batten (outside overlap zones).  
Install two flashing hooks to provide vertical retention while allowing thermal movement.



##### Step 2 - Intermediate flashings

Install flashings from right to left, following water run-off.

##### For each flashing:

- Fasten the left edge only with two screws
- Install two flashing hooks for vertical retention.

Flashings must overlap until upper folds meet.  
Minimum overlap: 200 mm, adjusted to roof pitch and exposure. No sealant or adhesive required.

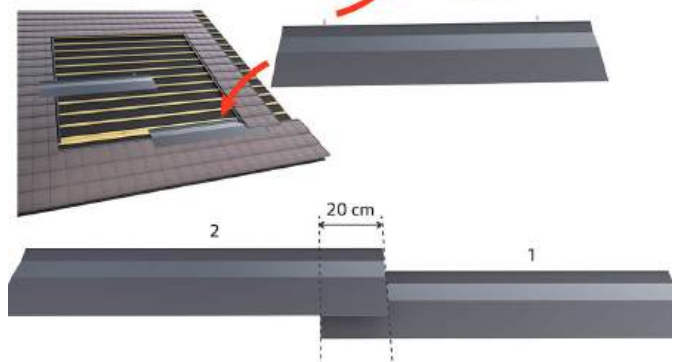

##### Step 3 - Left-hand corner

Cut the final flashing to length.  
Form a 20 mm lateral return to create the left-hand water barrier. Install using flashing hooks only, with no fixings in overlap zones.

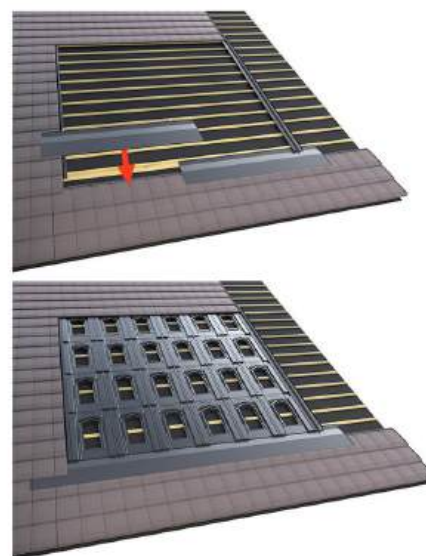

##### Waterproofing principle

Watertightness is ensured by flashing geometry, compliant overlaps and gravity drainage.  
Fixings and hooks provide retention only and must not interfere with water flow.

### EAVES AND FLASHING INSTALLATION

#### INSTALLATION OF THE LOWER RIGID FLASHING FOR FLAT TILE OR SLATE ROOFS

##### PREPARATION OF BATTENS

###### Lower PV Field Connection

Support battens must be installed to receive the rigid or semi rigid flashing forming the weatherproof junction between the lower edge of the PV array and the roof covering, in accordance with BS 5534, NHBC Technical Requirements and BBA-accepted roofing practice.

**The flashing ensures continuity of waterproofing and gravity-driven drainage onto the lower roof covering.**

##### REQUIREMENTS

- Maximum batten thickness: 18 mm
- Batten geometry adapted to roof pitch (no counter-slope)
- Batten layout defines the clearance between the PV field and the roof covering

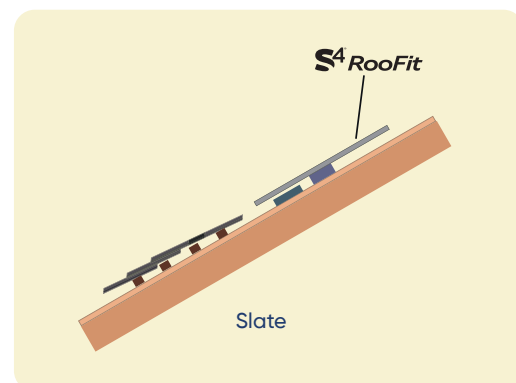
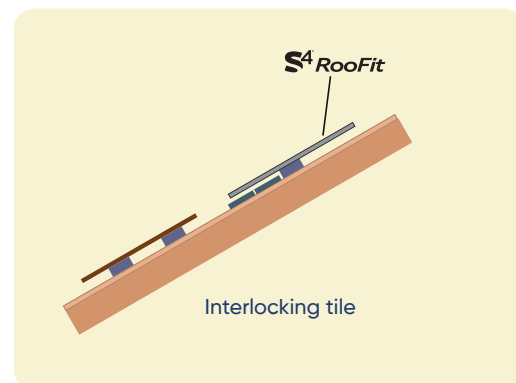

## EAVES AND FLASHING INSTALLATION

### PHOTOVOLTAIC INSTALLATION AT EAVES LEVEL

When the **photovoltaic array extends down** to the eaves, directly above the gutter and without a lower row of tiles, the installation of an **eaves flashing** (eaves trim) is **strongly recommended**.

The eaves flashing shall be installed **in accordance with BS 5534, NHBC Technical Requirements** and recognised UK roofing good practice, ensuring continuity of drainage into the gutter.

#### THE EAVES FLASHING PROVIDES:

- **Controlled drainage** of rainwater and condensation into the gutter,
- **Long-term protection** of the fascia board,
- **A clean and durable finish** at the lower edge of the PV array.



Eaves flashing

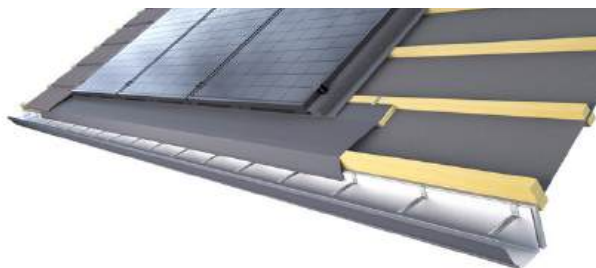

#### EAVES CONNECTION (GUTTER)

For **eaves-level installations**, a dual drip-edge configuration is recommended:

- **PV Drip Edge:** directs rainwater from the photovoltaic array into the gutter,
- **Underlay Drip Edge:** drains condensation and incidental water from the roofing underlay into the gutter.

#### WATERPROOFING PRINCIPLE

Watertightness at the eaves is ensured by geometry, overlaps and gravity-driven drainage.

**Drip edges** provide mechanical water guidance and must not rely on sealants or adhesives as the primary waterproofing method.

### EAVES AND FLASHING INSTALLATION

#### PHOTOVOLTAIC INSTALLATION AT EAVES LEVEL

##### ■ INSTALLATION AT EAVES LEVEL – PV ARRAY

Where the photovoltaic array extends to the eaves:

- The lower flashing shall be supported by continuous battens,
- Water must discharge freely and exclusively by gravity into the gutter,
- The flashing must not be bonded, fixed or restrained within the gutter.

A separate eaves flashing or drip edge shall be provided to evacuate any water or condensation from beneath the roofing underlay into the gutter.

##### ■ WATERPROOFING PRINCIPLE

Watertightness is achieved through correct flashing geometry, compliant overlaps and continuous gravity-driven drainage.

Any adhesive or butyl strip provides secondary sealing only and must not replace the fundamental principles required by BS 5534, NHBC and BBA guidance.

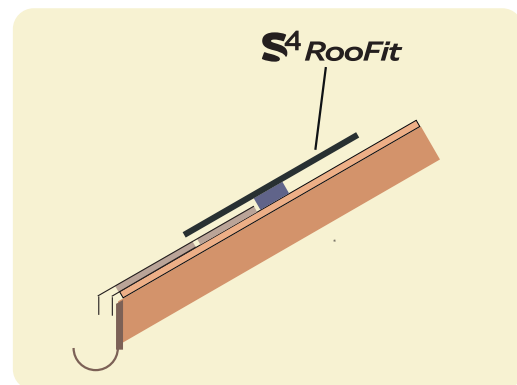

## FLASHING STRIP INSTALLATION

### Implementation of lower PV field connections in the main (central) section of the roof

#### Flexible Flashing with Butyl Strip – Lower Section Installation (Aluminium / Lead / EPDM)

##### 1. Corner preparation

Form the right-hand corner by folding the lateral edge back by approx. 20 mm to create a vertical return acting as a lateral water barrier, in accordance with UK roofing good practice (BS 5534, NHBC). Form the fold carefully to preserve material flexibility.

##### 2. Flashing installation

Position the flashing at the lower right-hand end of the PV array and install from right to left, following the direction of water runoff.

The flashing must extend:

- Upslope beneath the PV system to collect runoff,
- Downslope to discharge water onto the roof covering or into the gutter.

Provide a minimum overlap of 170 mm, increased where required depending on roof pitch and exposure.

##### 3. Bonding (butyl strip)

Ensure tiles/slates are clean, dry and free of debris.

Remove the protective film and press the flashing firmly onto the roof covering. Use a pressure roller to ensure uniform adhesion and long-term durability.

**NOTE:** The butyl strip provides supplementary sealing only and does not replace correct overlaps, flashing geometry or gravity-driven drainage.

##### 4. Left-hand corner

Cut the final length and fold the lateral edge back by approx. 20 mm to form the left-hand water barrier.

##### Waterproofing principle

Watertightness is achieved by correct flashing geometry, compliant overlaps and gravity-driven water flow.

No additional sealants or mastics are required when installed in accordance with these instructions and recognised UK roofing practice

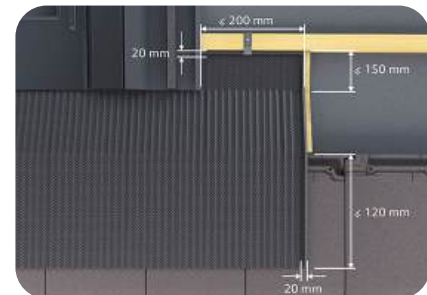

Flashing Strip

Type of strip	Recommended use	Average thickness	Remarks
Corrugated aluminium	Tiled or slate roofs	0,14 – 0,2 mm	Lightweight, durable, butyl adhesive backing
Lead	Slate roofs, flat tiles	0,5 mm	Excellent longevity, heavy material
EPDM	Mechanical tiles and special junctions	1,2 – 1,5 mm	Highly UV-resistant
Bitum	Temporary or sheltered use	–	Highly UV-resistant

## FLASHING STRIP INSTALLATION

### PHOTOVOLTAIC INSTALLATION AT THE LOWER JUNCTION WITH TILES OR SLATES

#### BATTEN PREPARATION – Lower PV Field Connection

The flashing is installed at the lower edge of the photovoltaic array to ensure continuity of roof waterproofing and controlled, gravity-driven drainage onto the lower roof covering.

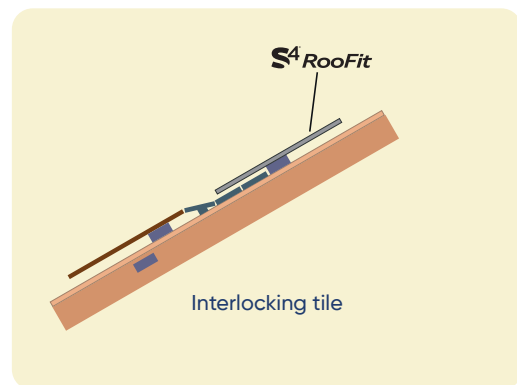

#### TILED ROOFS (flat, interlocking or profiled tiles)

A compensation (chamfered) batten must be installed to accommodate the tile profile and provide a flat, continuous support for the flashing, without creating counter-slope or water retention.

**Maximum batten thickness: 18 mm, adapted to the roof pitch.**

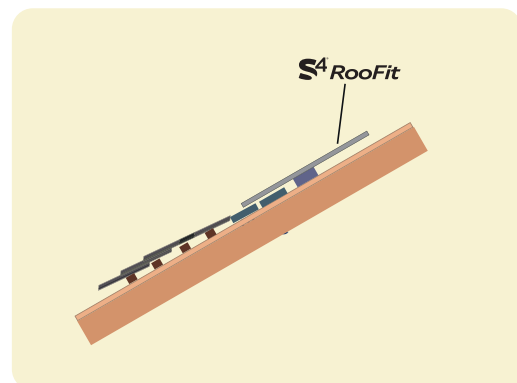

#### SLATE ROOFS

No compensation batten is required. The flashing must be supported by flat, continuous battens providing uniform bearing and uninterrupted water flow.

Installation in accordance with BS 5534, NHBC Technical Requirements and recognised BBA-accepted roofing practice.

### S4 HEIGHT RISER – TILE & SLATE

#### S4 HEIGHT RISER - TILE & SLATE

Installation of the S4 HEIGHT RISER Accessory Upper section of the photovoltaic array

The **S4 HEIGHT RISER** accessory must be installed on the uppermost row of S4 tray, corresponding to the area that will be covered by the roof covering elements (tiles or slates).

At the locations identified by the integrated circular markings on the S4 tray, carry out a pre-drilling operation using a 10 mm diameter drill bit.

This pre-drilling allows the secure clipping of the S4 HEIGHT RISER accessory into the **S4 Tray**, without inducing excessive mechanical stress.



#### THE S4 HEIGHT RISER FEATURES A STEPPED HEIGHT PROFILE:

- 20 mm at the front,
- 10 mm at the rear.

#### THIS GEOMETRY IS DESIGNED TO:

- Compensate for the lateral undulations of the S4 tray,
- Ensure correct and stress-free support of the roof covering elements,
- Prevent deformation, lifting or hard points in the tiles or slates,
- Maintain the continuity of the roof covering line, in accordance with good roofing practice.

#### MANDATORY COMPLEMENTARY PROVISION

The installation of the **S4 HEIGHT RISER** accessory does not replace the installation of the pre-compressed sealing strip.

The pre-compressed sealing strip must be installed at the lower edge, directly along the bottom edge of the S4 HEIGHT RISER accessory, in accordance with the system installation requirements.

#### THIS PROVISION IS ESSENTIAL TO ENSURE:

- Continuity of water and air tightness
- Accommodation of dimensional tolerances
- Long-term durability of the junction between the photovoltaic array and the roof covering.

All of these measures contribute to compliance with the requirements for continuous weatherproofing, material compatibility, and long-term performance, in accordance with BBA, MCS012, and applicable roofing standards.



### INSTALLATION WITH CUTTING OF SLATES AND FLAT TILES

#### INSTALLATION WITH CUTTING OF SLATES AND FLAT TILES



#### **! ALTERNATIVE INSTALLATION – WITHOUT S4 HEIGHT RISER**

If the S4 HEIGHT RISER accessory is not installed, slates or flat tiles may be cut to form the upper transition.

In this case, the use of a flashing strip is mandatory to ensure:

- Continuous water drainage,
- Weatherproofing between the S4 trays and the cut roof covering,
- Long-term durability of the roof system.

The flashing must be installed in accordance with UK roofing good practice, BS 5534 / NHBC requirements, and the flashing manufacturer's instructions.

Failure to install a suitable flashing may result in water ingress and non-compliance.

### CONNECTING OPTIMIZERS-MICRO INVERTERS

#### Option 1: Passing the cables under S4 Mounting System



### OPTIMIZERS-MICRO INVERTERS

### CONNECTING OPTIMIZERS-MICRO INVERTERS

#### Option 2 : Passing the cables above S4 Mounting System

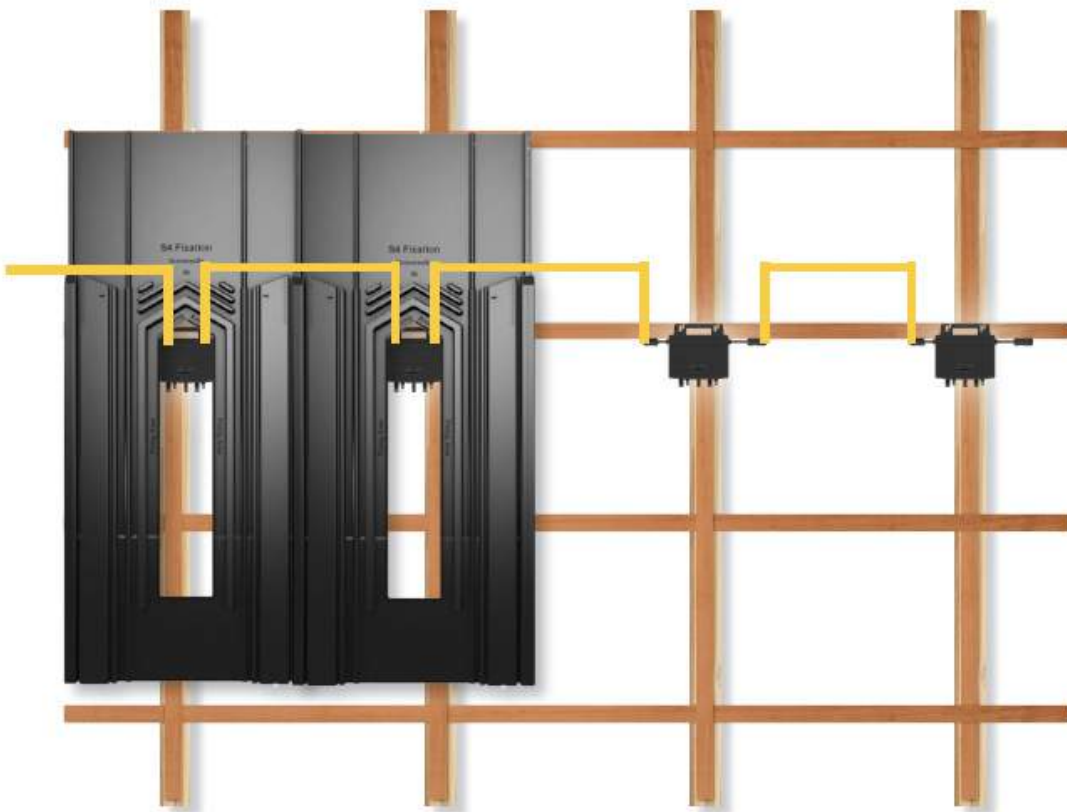

### OPTIMIZERS-MICRO INVERTERS

## INSTALLATION REQUIREMENTS

ON A BUILDING 15M HIGH, THE ENTIRE ROOF SURFACE CAN BE USED.  
ROOFING WORKS MUST BE CARRIED OUT BY A COMPETENT ROOFING PROFESSIONAL.



### EARTHING AND EQUIPOTENTIAL BONDING – GENERAL REQUIREMENTS

- The equipotential bonding of the photovoltaic installation must be maintained at all times.
- Earthing and bonding arrangements do not form part of the S4 mounting system installation and must be designed and installed by the installer in accordance with local regulations.
- The method of equipotential bonding shall comply with local regulations and the photovoltaic module manufacturer's requirements.

### COVER PREPARATION



**NOTE :** Connect to our layout calculator at: [www.S4mountingsystem.com](http://www.S4mountingsystem.com) to help you determine the exact field quotes.

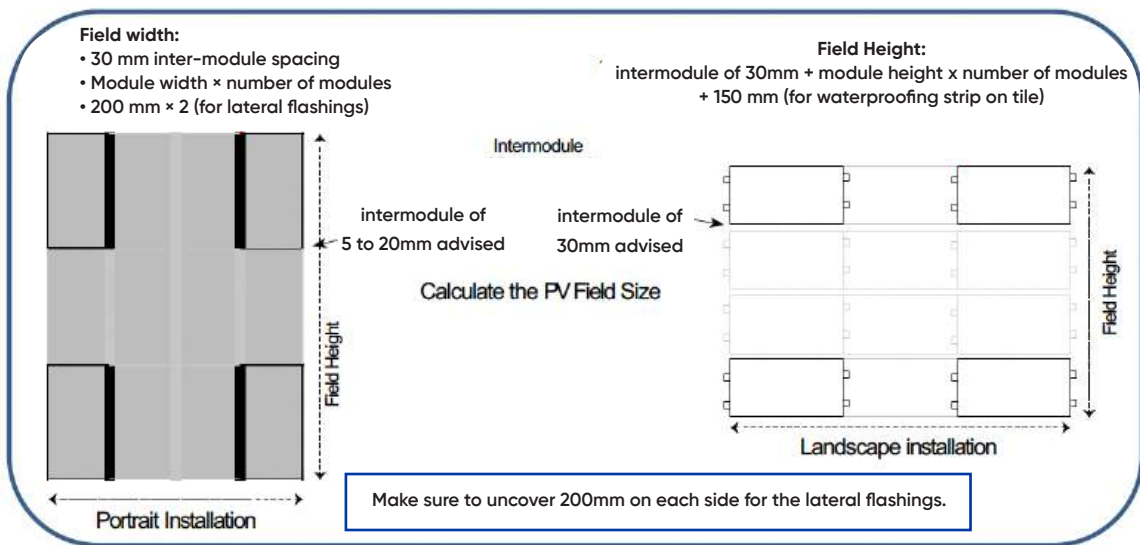

- 1- Remove the cover elements on the above-calculated width.
- 2- Take out an extra row of tiles on the left and on the right (2 rows for slate, or flat tiles)
- 3- Also remove the cover elements on the calculated height above.
- 4- Take out one row of tile on the top part (2 rows for slate or flat tiles)

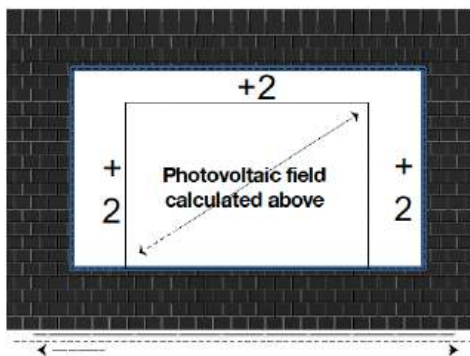

**SLATE ROOF**  
2 extra rows taken out.

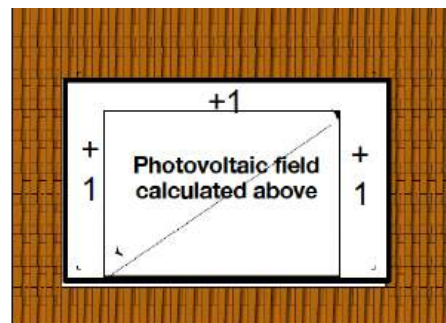

**TILE ROOF**  
1 extra row taken out

### INSTALLATION OF A ROOFING UNDERLAY

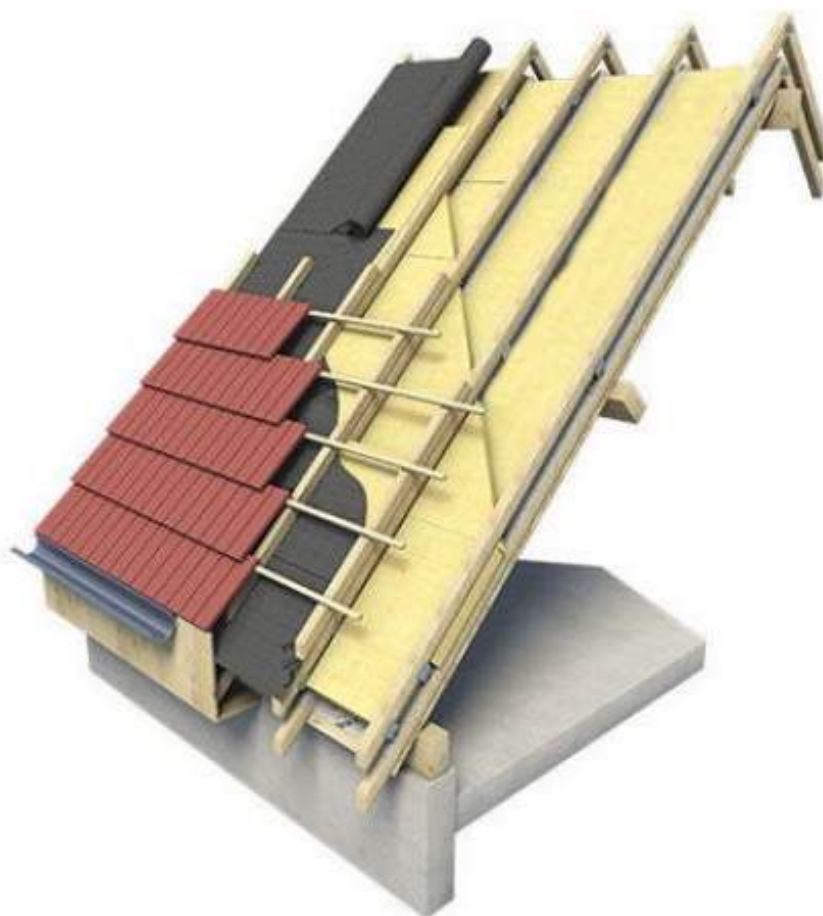

**NOTE:**

The installation of a roofing underlay must be carried out on the rafters in accordance with the European standard EN 13859-1.

Each European country may have additional national standards or regulations specifying the requirements and implementation methods adapted to their specific context.

### FLASHING STRIP INSTALLATION INSTRUCTIONS

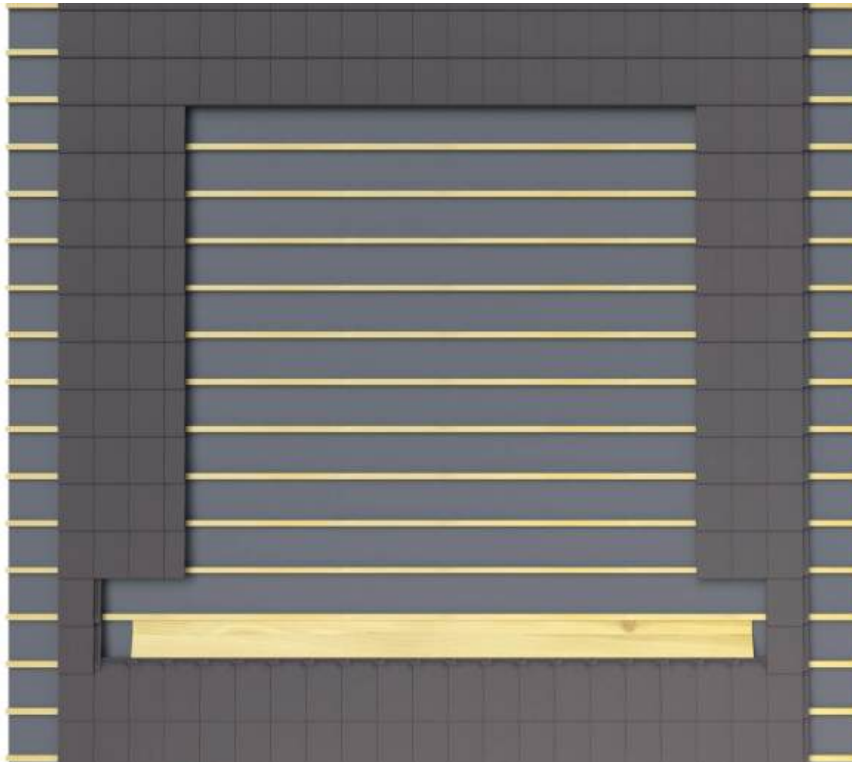

#### **i** INSTRUCTIONS:

Install support battens with a maximum thickness of 18 mm to receive the lower waterproofing strip. The battens must be extended by a minimum of 200 mm on each side of the photovoltaic array in order to ensure continuous support and effective weatherproofing beneath the lateral flashings.

This installation shall be carried out in accordance with BS 5534, NHBC Technical Requirements and BBA-accepted roofing practice.

Refer to pages 32 to 35 according to the installation configuration:

- Page 32: Semi-rigid flashing
- Page 33: Rigid flashing
- Page 34: Eaves-level installation
- Page 35: Flexible flashing



### EAVES AND FLASHING INSTALLATION

#### Implementation of lower PV field connections in the main (central) section of the roof

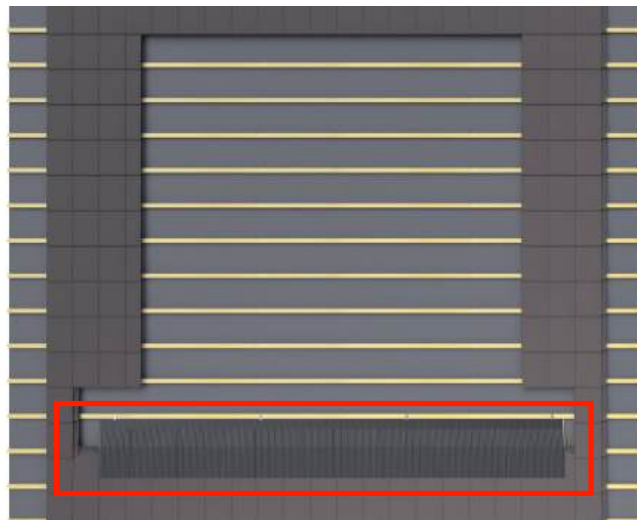

#### INSTALLATION OF THE LOWER WATERPROOFING STRIP

(Mid-roof installation – BBA / NHBC compliant)

- Cut the waterproofing strip to the full width of the PV array, allowing +200 mm overlap on each side to ensure continuity beneath lateral flashings.
- Form 20 mm upstands along the upper and lateral edges to prevent capillary ingress and guide water downslope.  
**Do not over-compress folds to allow thermal movement.**
- Remove the butyl protective film and install the strip onto the support battens, maintaining the natural roof fall.  
**Roof covering must be clean, dry and free from contaminants.**
- If required, temporarily secure the upper edge using fixing hooks only, outside water-exposed and overlap zones.
- Dress the strip firmly onto tiles or slates to follow the roof profile, using a pressure roller to avoid air pockets or water traps.

#### Waterproofing principle

The butyl strip provides secondary sealing only. Primary watertightness is ensured by correct flashing geometry, compliant overlaps, roof pitch and gravity-driven drainage.

- ✓ Compliant with BS 5534, NHBC requirements
- ✓ Suitable for BBA / MCS012 documentation



### BATTENING PLAN FOR LANDSCAPE PHOTOVOLTAIC PANEL INSTALLATION

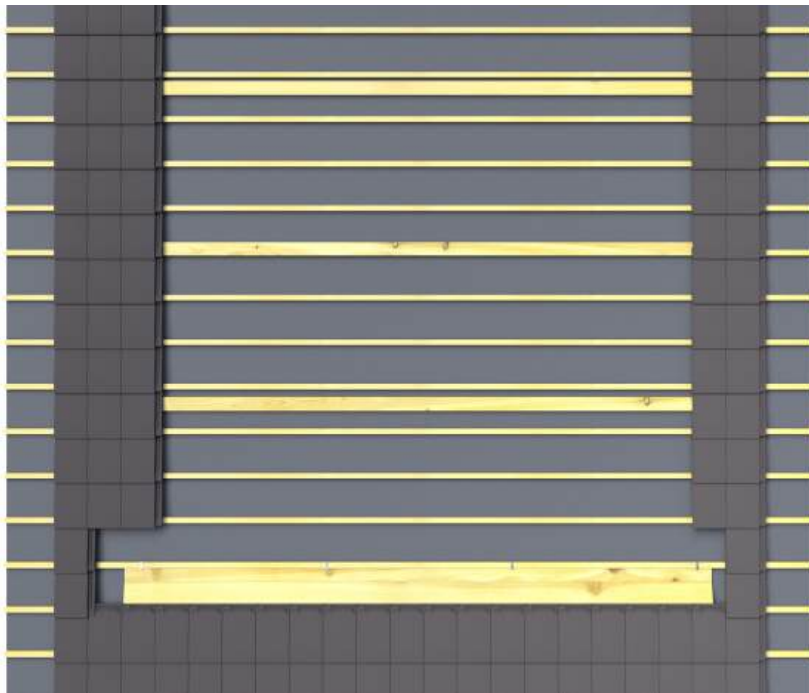

**⚠ INSTRUCTIONS REFER P.23:**

Place a 100 mm wide batten, matching the thickness of the existing batten, along the two long edges of the panel where the clamps will be attached.

For landscape installation, position the battens at a distance equal to the panel height (width / short side)

**EXAMPLE:**

If the panel height in landscape orientation is 1134 mm, set a 1134 mm gap between the two battens.

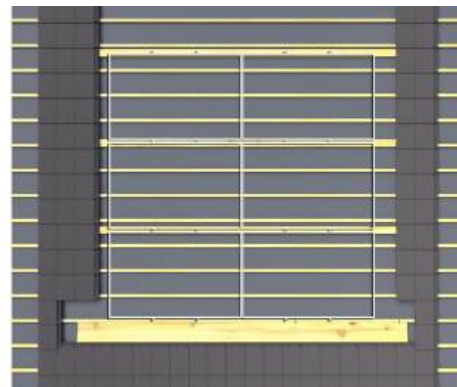

### BATTENING PLAN FOR LANDSCAPE PHOTOVOLTAIC PANEL INSTALLATION

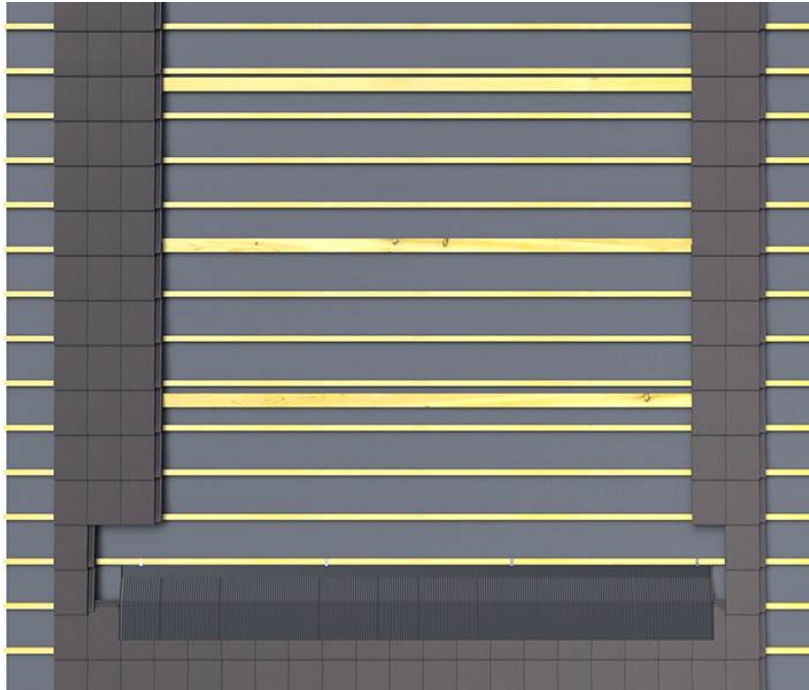

**⚠ INSTRUCTIONS REFER P.23:**

Place a 100 mm wide batten, matching the thickness of the existing batten, along the two long edges of the panel where the clamps will be attached.

For landscape installation, position the battens at a distance equal to the panel height (width / short side)

**EXAMPLE:**

If the panel height in landscape orientation is 1134 mm, set a 1134 mm gap between the two battens.

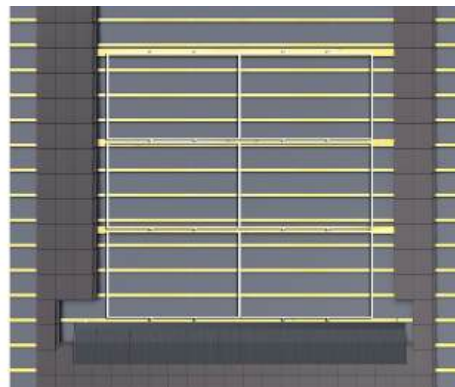

### LANDSCAPE PHOTOVOLTAIC PANEL INSTALLATION

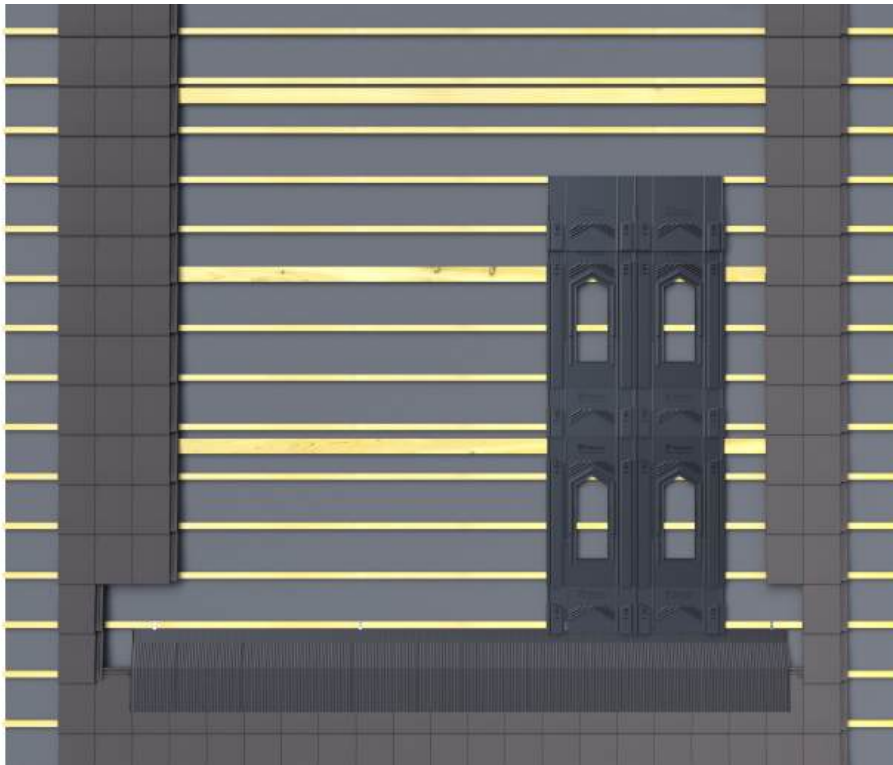

#### **i** INSTRUCTIONS

The overlap of the S4 tray over the flashing strip shall be a minimum of 150 mm and increased where required depending on roof pitch, roofing type and recognised roofing good practice.

Where necessary, a pre-compressed sealing strip may be added as a supplementary measure to improve water and air management;

This seal provides secondary sealing only and does not replace the minimum required overlap or recognised roofing standards.

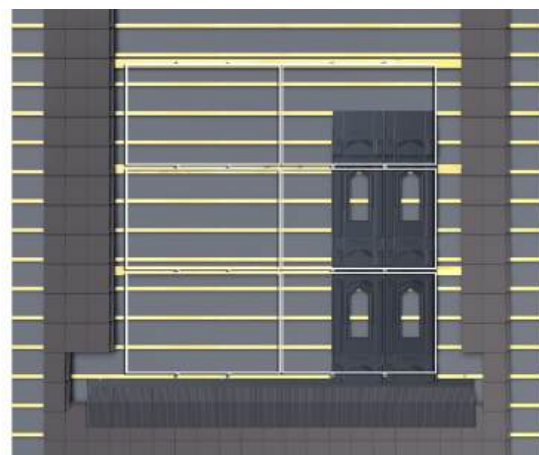

### LANDSCAPE PHOTOVOLTAIC PANEL INSTALLATION

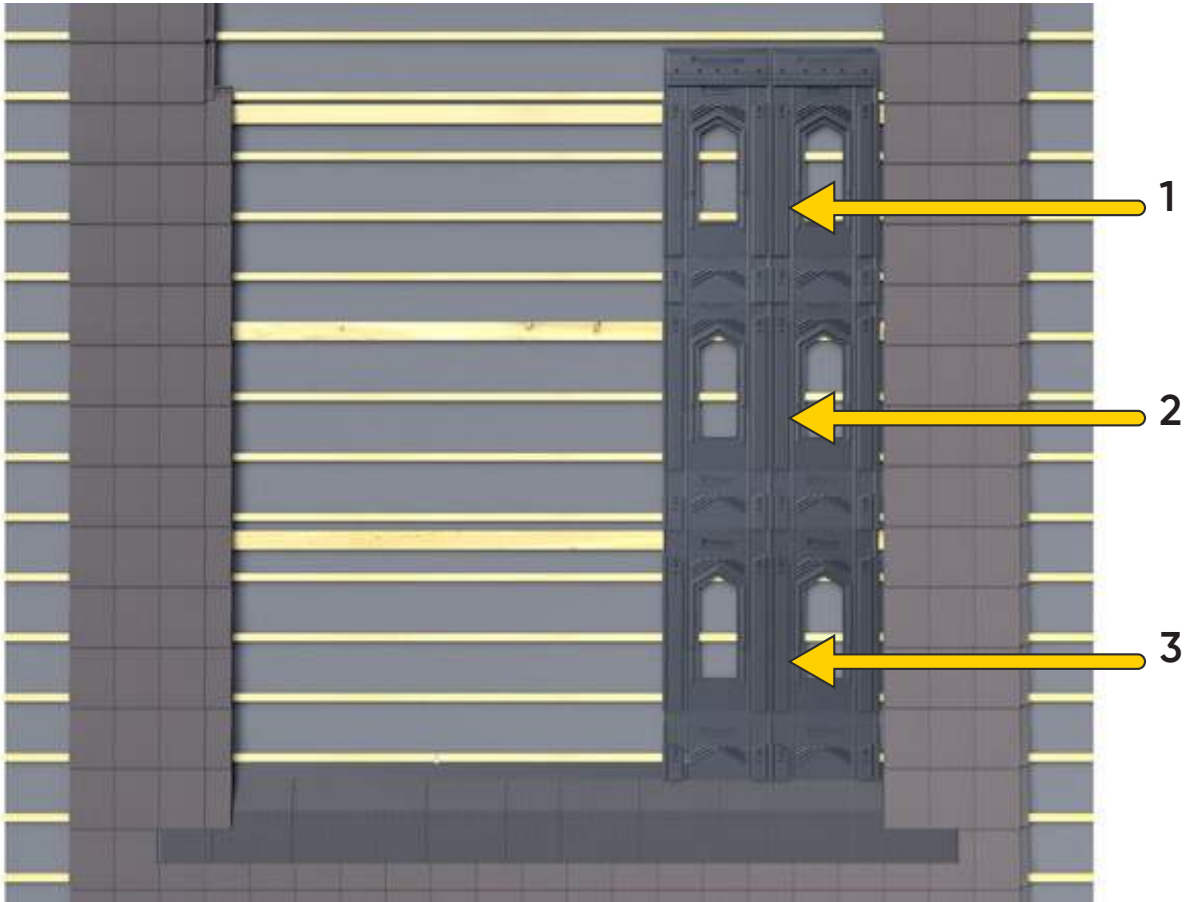

#### INSTRUCTIONS:



Install the S4 trays from right to left, starting with the bottom row, and ensure proper overlapping.

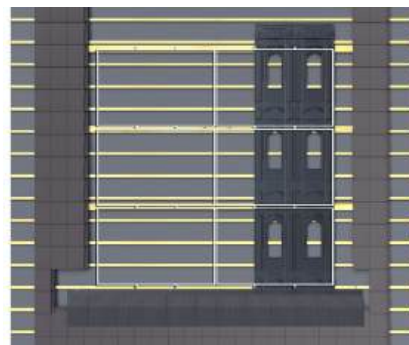

### LANDSCAPE PHOTOVOLTAIC PANEL INSTALLATION

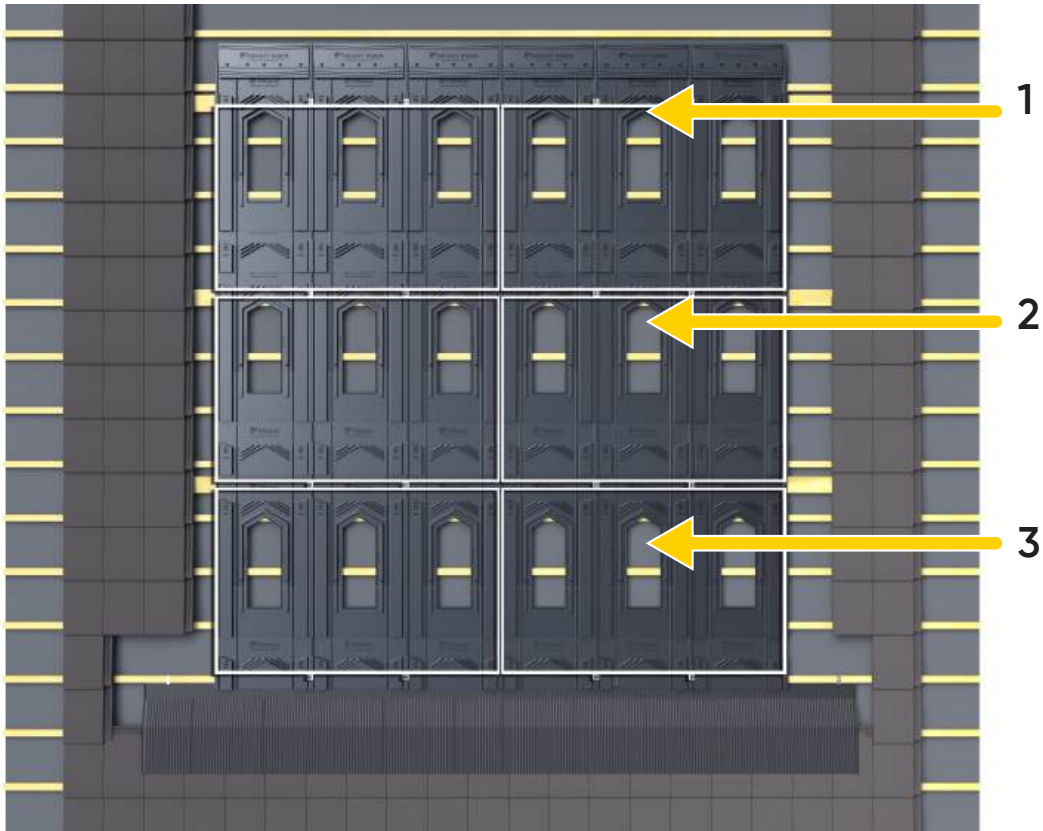

Zoom view



Zoom view



THE S4 MOUNTING SYSTEM REQUIRES LATERAL ADAPTATORS TO BE POSITIONED AT THE EXTREMITIES OF THE PV ARRAY

### LANDSCAPE PHOTOVOLTAIC PANEL INSTALLATION

The S4 mounting system requires lateral adaptators to be positioned at the extremities of the PV array



#### IMPORTANT:

##### Wave management at array edges

- The left wave of the S4 trays is reinforced.
- The right wave is not reinforced and overlaps the left wave of the adjacent right-hand tray.

##### Right-hand edge of the array

At the right-hand end of the array, the right wave is therefore not reinforced.

The reinforced right End of Array wave must be positioned underneath the right wave in order to:

- Provide proper mechanical reinforcement,
- Ensure correct clamp support,
- Guarantee overall system stability.

##### Left-hand edge of the array

The left wave is intentionally 2.5 mm lower to allow tray overlap.

At the left-hand edge of the installation, the left End of Array wave must be installed in order to:

- Compensate for the 2.5 mm height difference,
- Provide a flat and level support,
- Prevent the left clamp from tipping backwards.

**!** Without the left End of Array wave, a 2.5 mm support gap will remain, leading to clamp instability.

### LATERAL FLASHINGS INSTALLATION

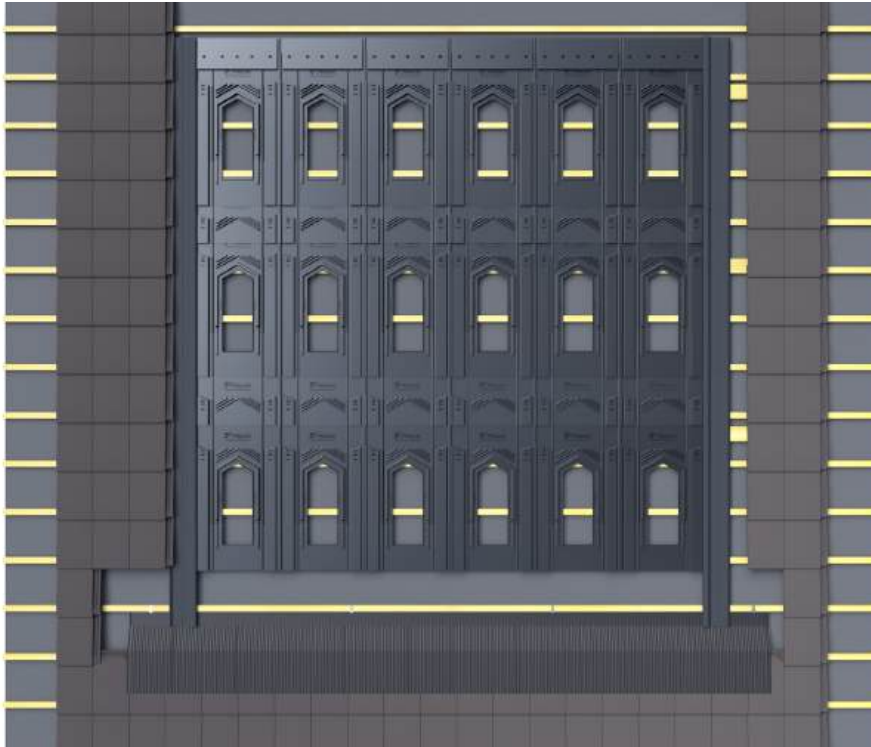

#### INSTRUCTIONS

1. Position the lateral flashings along the left- and right-hand edges of the S4 integration system, ensuring they properly overlap the S4 tray waves to maintain continuous weatherproofing.
2. At the overlap between two lateral flashings, fasten the flashings together using a 6.3 × 25 mm hexagonal head screw to ensure secure fixing and correct alignment.
3. Position the single clamp at the pre-marked location on the S4 mounting trays, ready for final fixing.

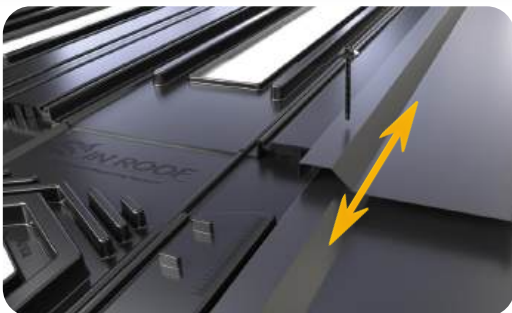

Overlapping of 15 cm



Black Lateral Flashing



The overlap of the flashings between each other must be 15 cm.

### LATERAL FLASHINGS INSTALLATION

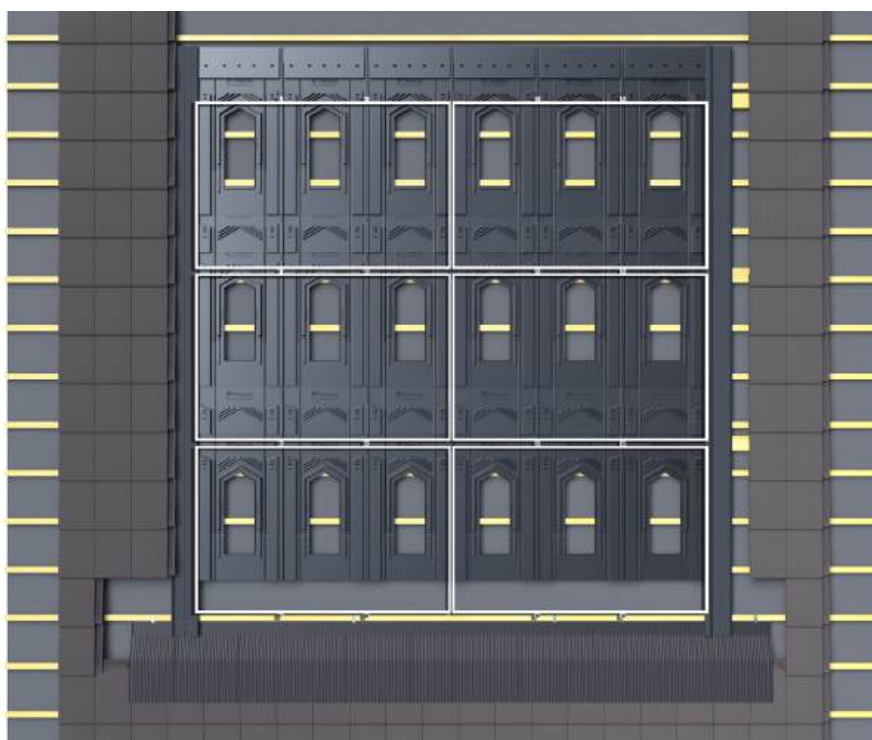

**THE FLASHINGS INTERLOCK WITH EACH OTHER,**

**with the top part over the bottom part to allow proper water drainage**

1. Open the lateral flashing hook over 10 to 15 cm (lower lateral flashing).
2. Interlock the upper lateral flashing on the lower one, then re-close the flashing hook.
3. Fasten the lateral flashing to the roof structure using the flashing hook.

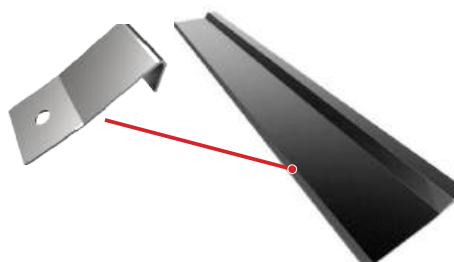

**To secure the lateral flashing, use the hook. Fasten the hook with a nail or a screw.**

## PRECOMPRESSED SEAL INSTALLATION

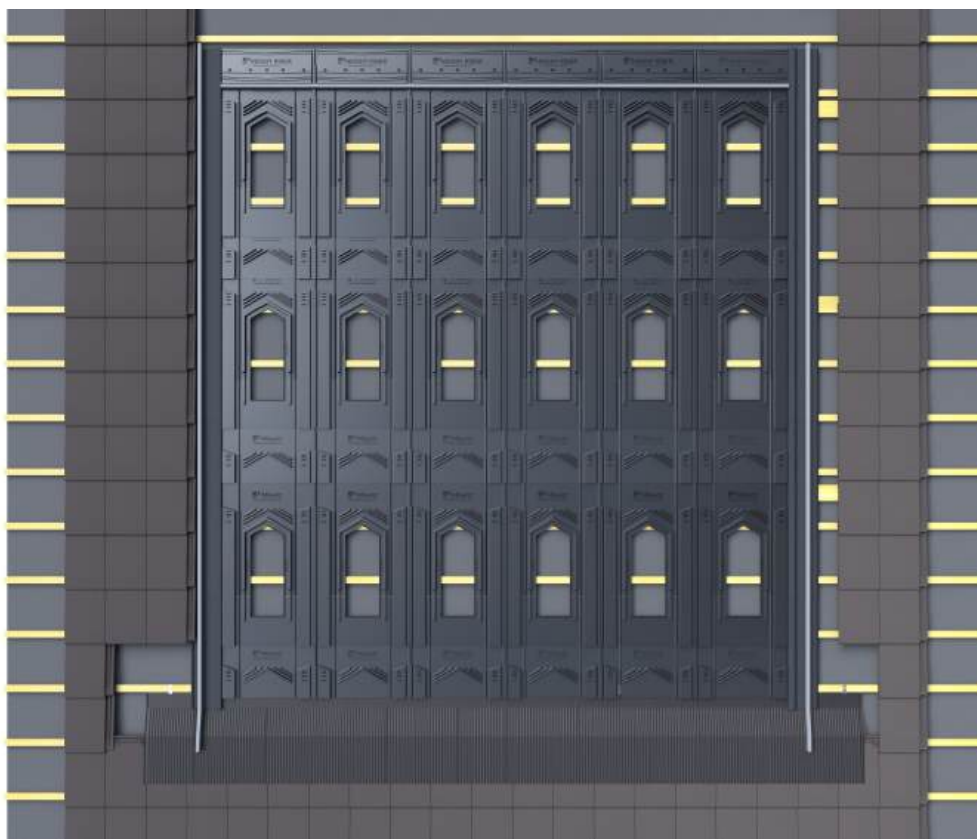

### **i** INSTALLATION OF THE PRE-COMPRESSED SEAL

**1. Unroll the pre-compressed seal** along the lateral flashings, starting from the top and working downwards, until reaching the bottom of the lower waterproofing strip.

**The seal must be continuous, fully jointed, and free of gaps.**

**2. Position the seal:**

- At a minimum of 20 mm from the outer edge of the lateral flashing,
- At least 30 mm from the edge of the S4 tray to maintain a clear drainage path for water.

**3. At the top of the installation,**

install the pre-compressed seal horizontally, at the base of the S4 Height Riser, across the overlap zone, to ensure continuous weatherproofing between the photovoltaic array and the roof covering.

#### LATERAL FLASHINGS INSTALLATION

REFER TO PAGE 35 - S4 HEIGHT RISER - TILE & SLATE



**i INSTRUCTIONS:**

Unroll and firmly bond the pre-compressed seal onto the S4 plate, positioning it directly at the base of the S4 Height Riser.

### REINSTALL THE ROWS OF TILES

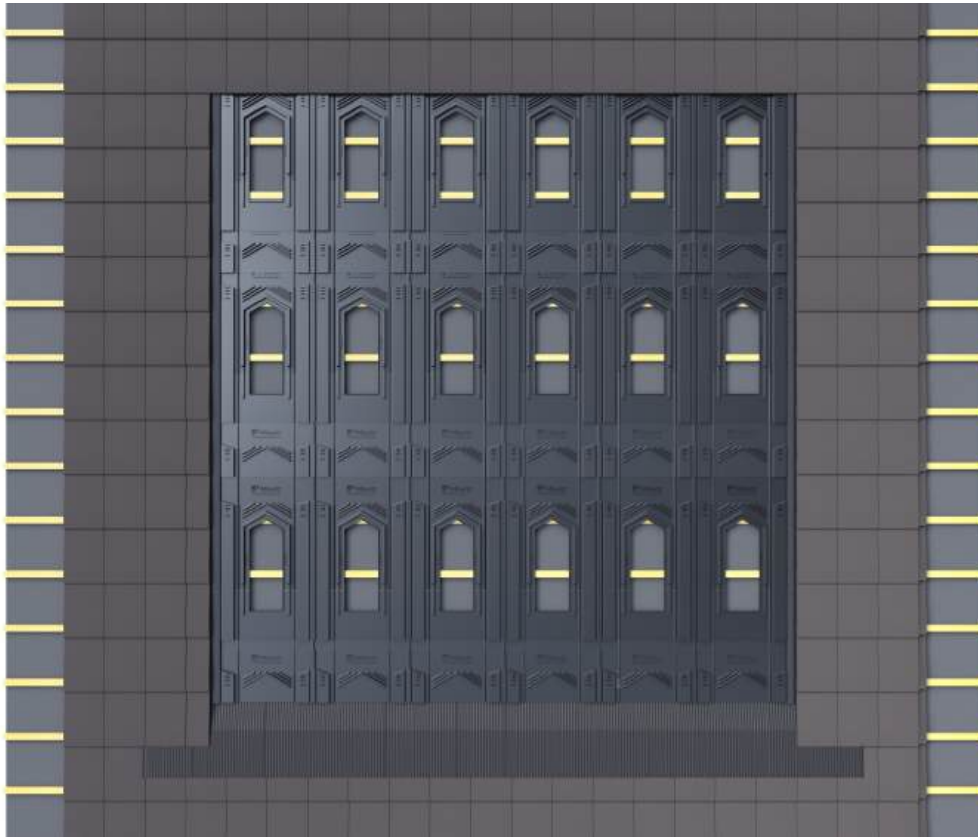

**INSTRUCTIONS:**

Reposition the rows of tiles or slates above the lateral flashings and at the top.

### LANDSCAPE PHOTOVOLTAIC PANEL INSTALLATION

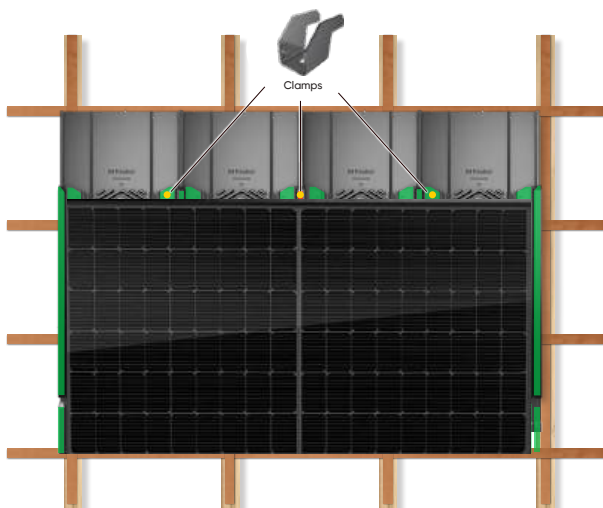
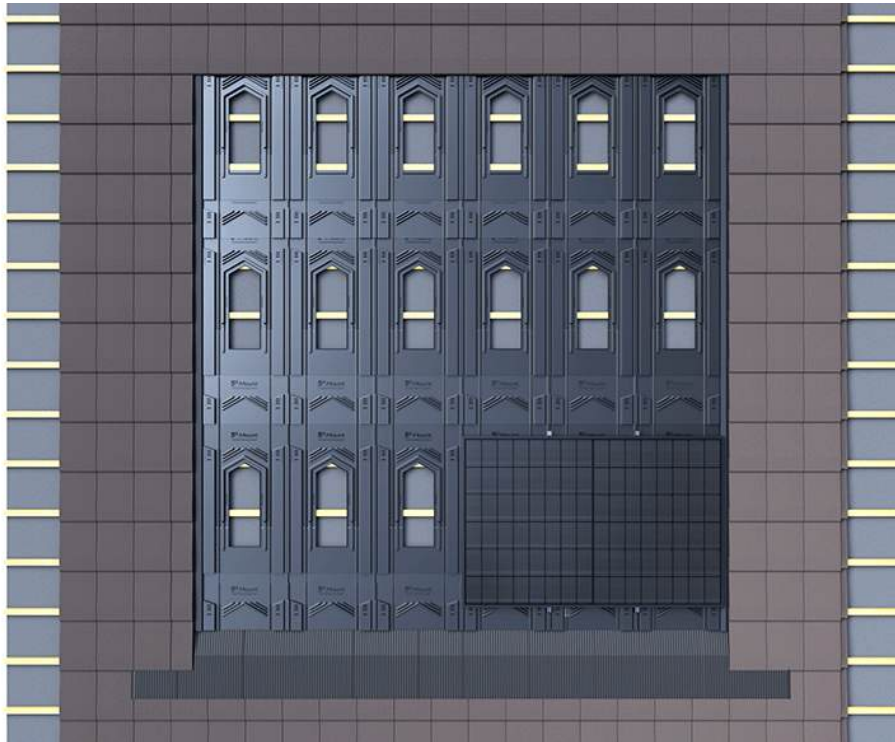

⚠ Refer P. 22 - 23

#### FASTENING THE CLAMPS ON THE TRAYS

The choice of clamps depends on the wind zone requirements and must comply with the PV module manufacturer's guidelines.

Most PV modules are rated for wind pressure resistance up to 2400Pa.  
Reinforced clamps can withstand up to 3400Pa; however, manufacturer approval is required to exceed 2400Pa.

For accurate configuration, refer to the S4 Mounting System online configurator.

⚠ **IMPORTANT:** Make sure to fix the clamps on the wood battens.

### LANDSCAPE PHOTOVOLTAIC PANEL INSTALLATION

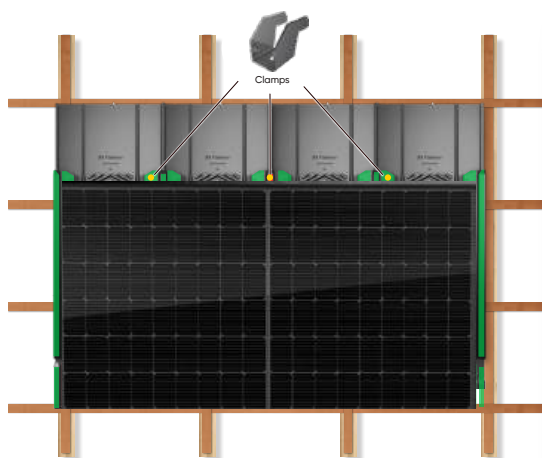
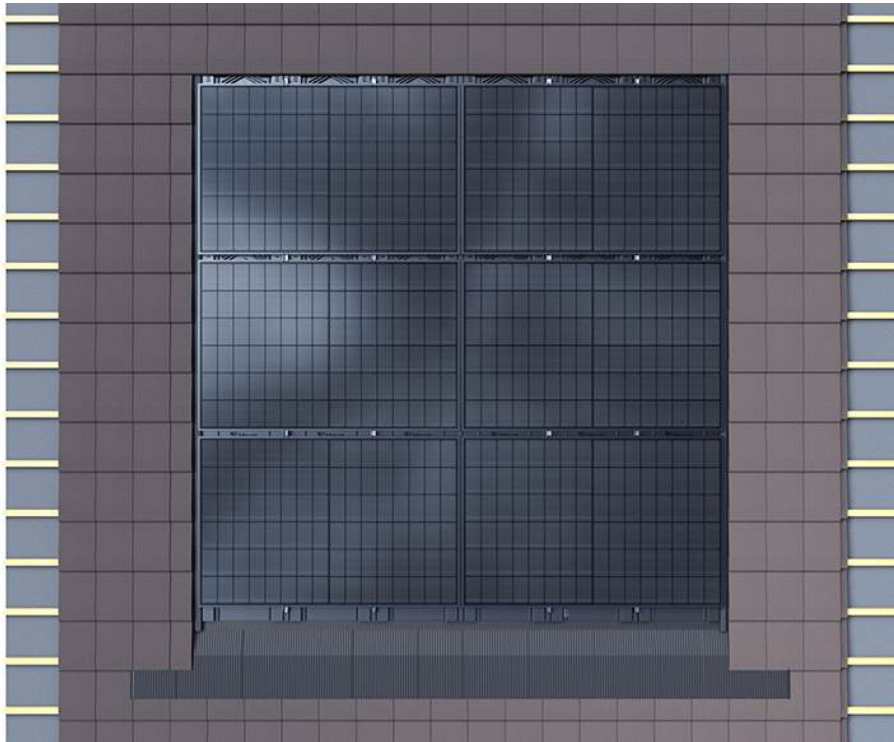

⚠ Refer P. 22 - 23

#### FIXING THE CLAMPS ON THE TRAYS

The choice of clamps depends on the wind zone requirements and must comply with the PV module manufacturer's guidelines.

Most PV modules are rated for wind pressure resistance up to 2400Pa. Reinforced clamps can withstand up to 3400Pa; however, manufacturer approval is required to exceed 2400Pa.

For accurate configuration, refer to the S4 Mounting System online configurator.

⚠ Make sure to fix the clamps on the wood battens.

#### LANDSCAPE PHOTOVOLTAIC PANEL INSTALLATION



**! IMPORTANT**

The overlap between the S4 trays and the flashing components (including flexible, semi-rigid and rigid flashing systems) must be determined in accordance with good roofing practice, taking into account the roof pitch, to ensure correct weathering and water run-off.

**Roofing works, including the selection and determination of the appropriate overlap for all flashing types, must be carried out by a competent roofing professional.**

### ■ PORTRAIT PHOTOVOLTAIC PANEL INSTALLATION

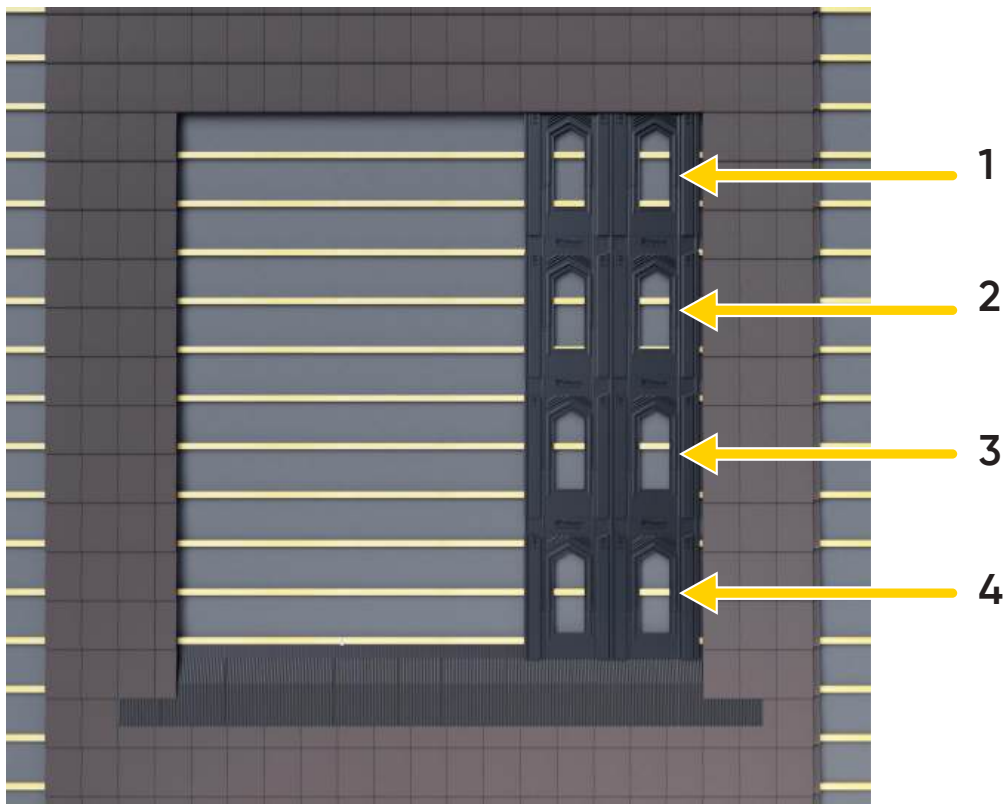

#### INSTRUCTIONS

install the trays from right to left, starting with the bottom row, and ensure proper overlapping.

### ■ PORTRAIT PHOTOVOLTAIC PANEL INSTALLATION

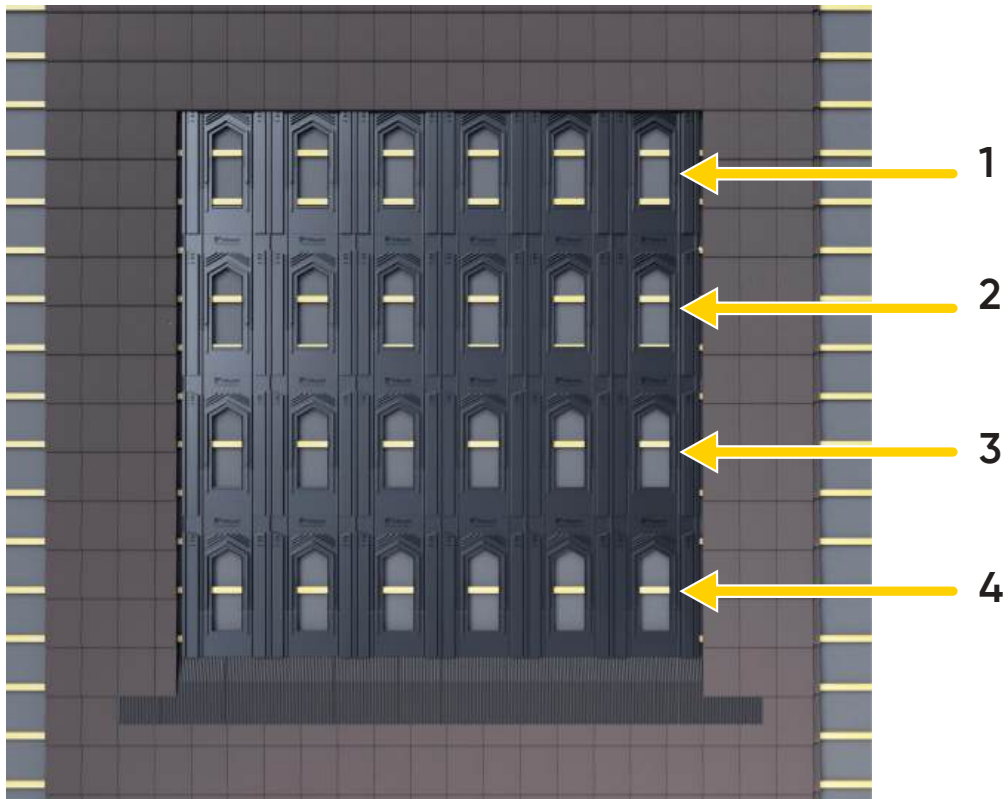

#### INSTRUCTIONS:

Install the trays from right to left, starting with the bottom row, and ensure proper overlapping.



#### IMPORTANT

Please refer to pages 53 to 57 for the installation of the lateral flashings, the pre-compressed seal, and then reinstall the rows of tiles after fitting the S4 HEIGHT RISER (page 39).

### ■ PORTRAIT PHOTOVOLTAIC PANEL INSTALLATION

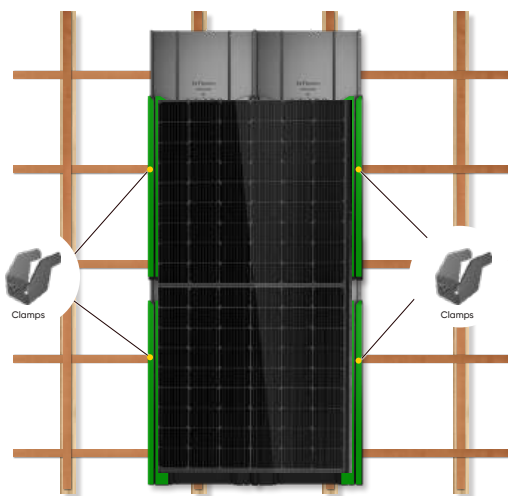

#### ■ FASTENING THE CLAMPS ON THE MOUNTING TRAYS

The choice of clamps depends on the wind zone requirements and must comply with the PV module manufacturer's guidelines.

Most PV modules are rated for wind pressure resistance up to 2400Pa. Reinforced clamps can withstand up to 3400Pa; however, manufacturer approval is required to exceed 2400Pa.

For accurate configuration, refer to the S4 Mounting System online configurator.

**!** **IMPORTANT:** Make sure to fix the clamps on the wood battens.

### ■ PORTRAIT PHOTOVOLTAIC PANEL INSTALLATION

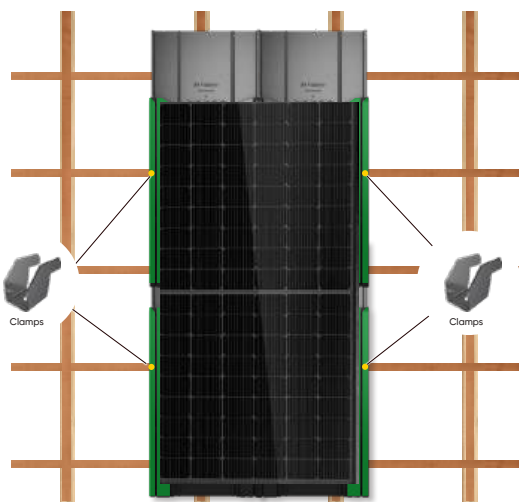
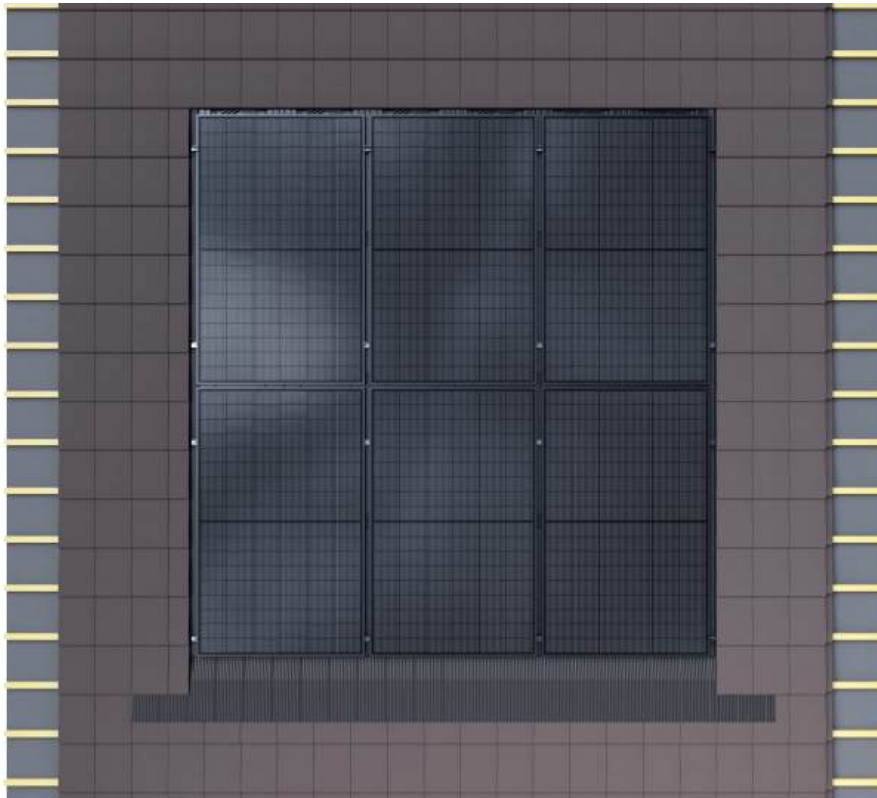

#### ■ FIXING THE CLAMPS ON THE MOUNTING TRAYS

The choice of clamps depends on the wind zone requirements and must comply with the PV module manufacturer's guidelines.

Most PV modules are rated for wind pressure resistance up to 2400Pa. Reinforced clamps can withstand up to 3400Pa; however, manufacturer approval is required to exceed 2400Pa.

For accurate configuration, refer to the S4 Mounting System online configurator.

**!** **IMPORTANT:** Make sure to fix the clamps on the wood battens.

### ADAPTATION METHOD TO DEAL WITH TOLERANCE

#### DIMENSIONAL TOLERANCES

As with any industrial product, slight dimensional variations may occur between manufactured components. These variations, known as tolerances, are inherent to the production process and apply both to photovoltaic panels and to the components of the S4 Mounting System.

They are generally within  $\pm 2$  mm, and may result from several factors, such as:

- Thermal expansion of materials (aluminium, glass, polymers) during production,
- Manufacturing tolerances related to moulds, tools, or presses,
- Mechanical adjustments made during assembly or packaging, and natural variations in raw materials.

In practice, a tolerance of +1 mm at the start of a row does not create any issue on installations of 1 to 5 panels. However, over longer series, for example 8 to 10 consecutive panels, this small variation may accumulate and lead to a slight visual or dimensional offset.

To correct this easily during installation, a small horizontal extension can be added to restore the expected alignment and maintain consistent dimensions across the array.

Such adjustments are considered best installation practices and ensure both the technical integrity and the aesthetic quality of the S4 Mounting System.



Universal frame



Small horizontal extension

### UNIVERSAL INTERMODULE - BLACK

#### REGION-SPECIFIC

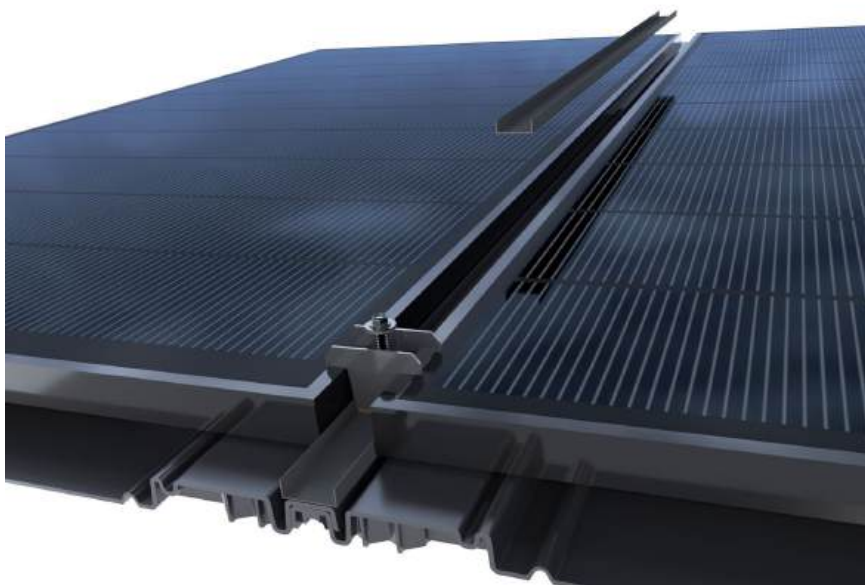

Install the Universal Intermodule BLACK between each row of panels.  
Make sure to replace the EPDM thickness with the 0.9 mm version.

### RECOMMENDATIONS FOR SCREW FASTENING

#### Minimum Distance Requirements for Screws in Softwood (Pine) and Edge Distance for Battens

Guidelines for Pine According to Eurocode 5 (EC5) & DIN 1052

#### Minimum Distance Between Two Screws (Center-to-Center Spacing):

- Maintain a minimum spacing of 3 times the screw diameter.

#### Why Follow the 3x Diameter Rule?

- Prevents wood splitting, especially in softwoods (resinous species).
- Preserves mechanical strength without compromising structural integrity.
- Ensures proper screw grip and prevents loosening.

#### Exceptions to the 3x Diameter Rule

- In specific scenarios, 3 times the diameter may be insufficient due to:
- High load requirements or vibration exposure.
- Close proximity to edges, which may weaken the wood.
- Special design constraints or structural requirements.



#### Distance Requirements for Screws in Hard or Dry Wood (e.g., Oak, Beech, Exotic Wood)

##### Hard or Dry Wood Recommendations:

- Use a minimum spacing of 4 times the screw diameter or pre-drill to prevent wood splitting.

##### Minimum Distance from the Edge:

- Maintain a distance of at least 2 times the screw diameter from the edge to avoid splitting.
- Example: For a 6 mm screw, place it at least 12 mm from the edge.

##### Additional Tips to Prevent Splitting:

- Pre-drill holes to reduce stress on the wood fibers.
- Use screws designed for hardwood to ensure better grip and reduce cracking.
- Avoid over-tightening, which can cause the wood to split.



##### Do not overtighten:

Excessive pressure can cause the wood to crack, especially if it is dry.

**Use wood screws with an anti-splitting tip (S4 screws recommended).**

For more details, in accordance with Eurocode 5 (EC5) and BS 5268.



### ■ ANNUAL MAINTENANCE INSTRUCTIONS:

---

#### 1. Inspect and Clean:

- Perform a yearly inspection for leaves and debris under the PV system.
- Remove debris using a compressed air blower.



#### Warning:

- Do not use solvents on polypropylene mounting trays.
- Only use approved cleaning methods for all system components.

#### 2. Regular Maintenance:

- Regular maintenance is required to ensure optimal performance.

#### 3. Recommended Annual Maintenance Contract:

- Offer an annual service to customers, including:
- Inspection of power generation and electrical systems.
- Checking PV panels, mounting trays, fixings, precompressed seals, and waterproofing strips.
- This proactive service enhances system longevity and efficiency.

### ■ REPLACING A MODULE

---

1. Power off the PV INSTALLATION.
2. Remove the clamps from the panel to be replaced.
3. Disconnect the earthing connection and disconnect it from the string.
4. Take out the panel that needs to be changed and replace it with the new one.
5. Connect the new panel to the earth and reconnect it to the string.
6. Put back the clamps.



#### THE EQUIPOTENTIAL BONDING MUST BE MAINTAINED

The method of equipotential bonding shall comply with local regulations and the photovoltaic module manufacturer's requirements.

### ■ TRAINING

---



Roofing works must be carried out by a competent roofing professional.  
Trainings can be organized with your distributor.  
Please contact your distributor for further information.

### ■ TECHNICAL ASSISTANCE

---

TECHNICAL ASSISTANCE IS AVAILABLE WITH YOUR DISTRIBUTOR  
OR FROM MONDAY TO FRIDAY AT THE CONTACT INFORMATION BELOW

#### **S4 MOUNTING SYSTEM**

- Customer Service: +33 9 55 17 82 59
- E-mail: [technical@s4mountingsystem.com](mailto:technical@s4mountingsystem.com)
- Web: [www.s4mountingsystem.com](http://www.s4mountingsystem.com)

# S4<sup>®</sup> RooFit<sup>™</sup>

Universal Mounting System



## S4 MOUNTING SYSTEM

55 Avenue Marceau 75016 Paris - France

Tel: +33 9 55 17 82 59

Mail: [contact@s4mountingsystem.com](mailto:contact@s4mountingsystem.com)

[www.s4mountingsystem.com](http://www.s4mountingsystem.com)